

Heat and Cold Energy Demands of Buildings

Module 2.6 Primary network

SHaKE – Sharing Heat and Knowledge on Energy Communities
Erasmus+ KA220-HED Cooperation Partnerships in HE
Developing institution: Mines Paris – PSL
Author: Dr. Antoine Fabre
Date: March 2026
Version 1.0



SHaKE

Sharing Knowledge on Energy Communities



1. Introduction

Once the consumption of the buildings is determined and the secondary network is sized, it is necessary to choose and size the substation

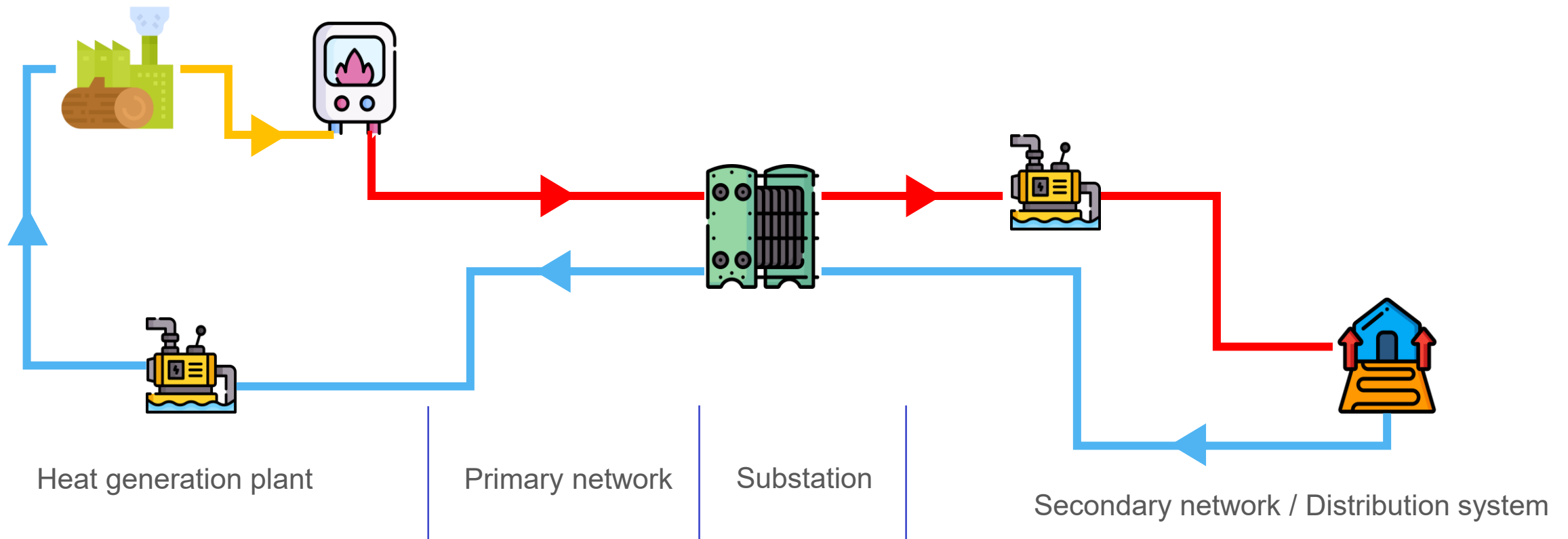

2. Substation components

The substation is the element at the interface between the primary and secondary networks. It enables the two sides of a heating network to be hydraulically separated. It is also the place where the energy use is calculated

A substation is composed of one or several:

Plate heat exchanger



Control valve



Sensors & controller



Heat meters



2. Substation components

Plate heat exchanger

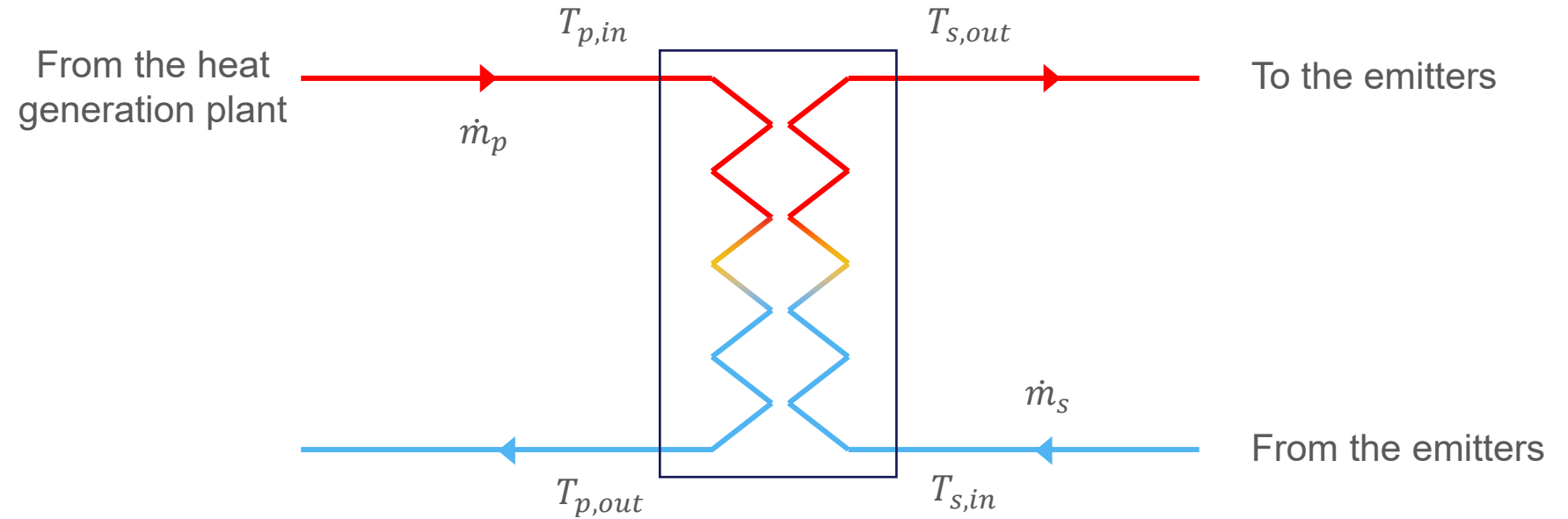

The plate heat exchanger is the most important element of the substation. It allows to separate and to enable the heat transfer between the primary and secondary side

$$\dot{Q} = \dot{m}_s C_p (T_{s,out} - T_{s,in})$$

$$\dot{Q} = \dot{m}_p C_p (T_{p,in} - T_{p,out})$$

$$E = \frac{\dot{Q}}{\min(\dot{m}_p C_p; \dot{m}_s C_p) (T_{p,in} - T_{s,in})}$$

2. Substation components

Plate heat exchanger

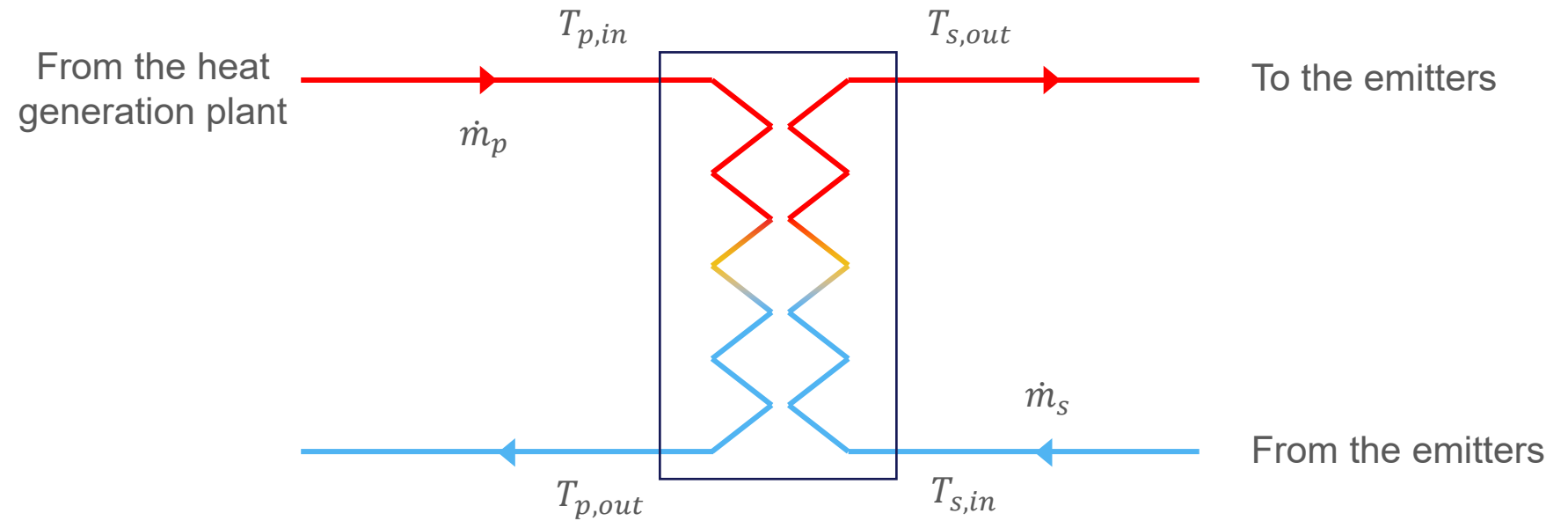

To ensure the best DHN performance the primary return temperature must be as low as possible. Hence, the pinch of the HEX must be the lowest possible

$$\text{We want } Pinch = \Delta T_{min} = T_{p,out} - T_{s,in} < 1^\circ C$$

$$\text{If } T_{p,in} - T_{s,out} > 1^\circ C \rightarrow \dot{m}_p < \dot{m}_s \text{ for } P = cst$$

2. Substation components

Plate heat exchanger

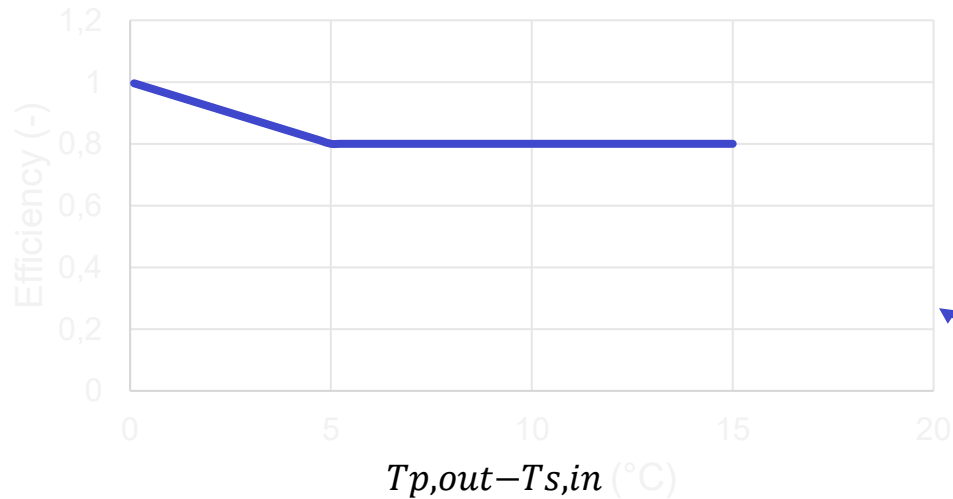
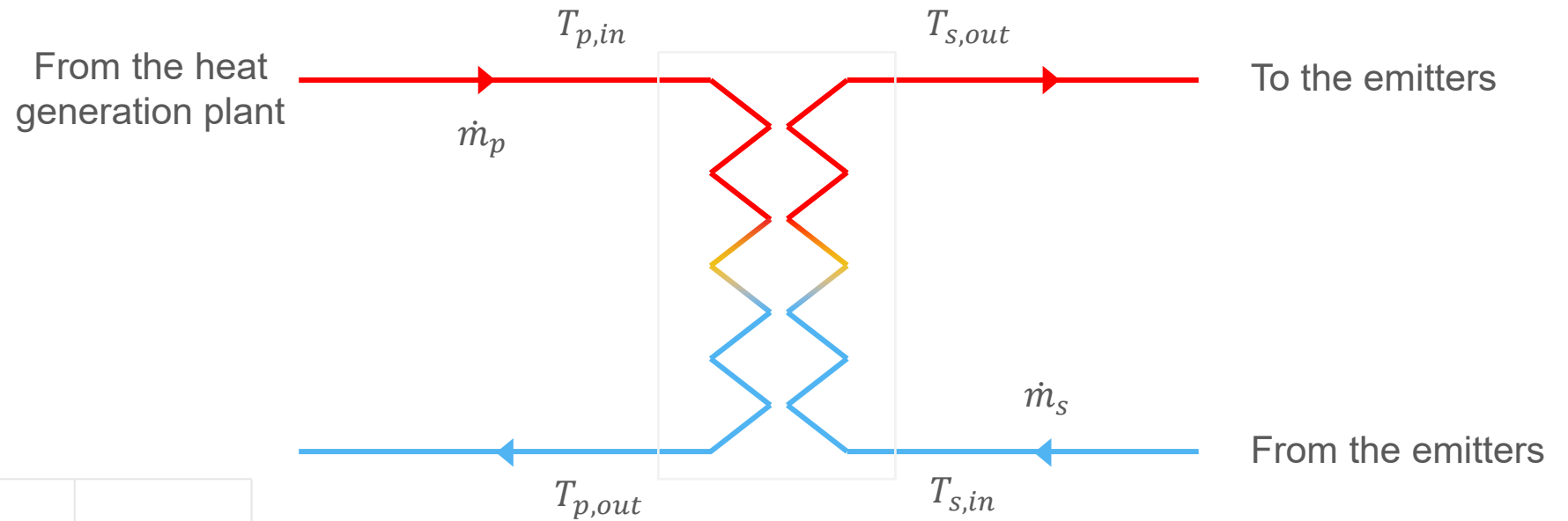

We want $\dot{m}_p < \dot{m}_s$ to have the pinch at the primary outlet

And we want $Pinch = \Delta T_{min} = T_{p,out} - T_{s,in} < 1^\circ C$

For $T_{p,in} = 85^\circ C, T_{s,out} = 80^\circ C, T_{s,in} = 60^\circ C, \dot{Q} = cst, \dot{m}_s = cst$

2. Substation components

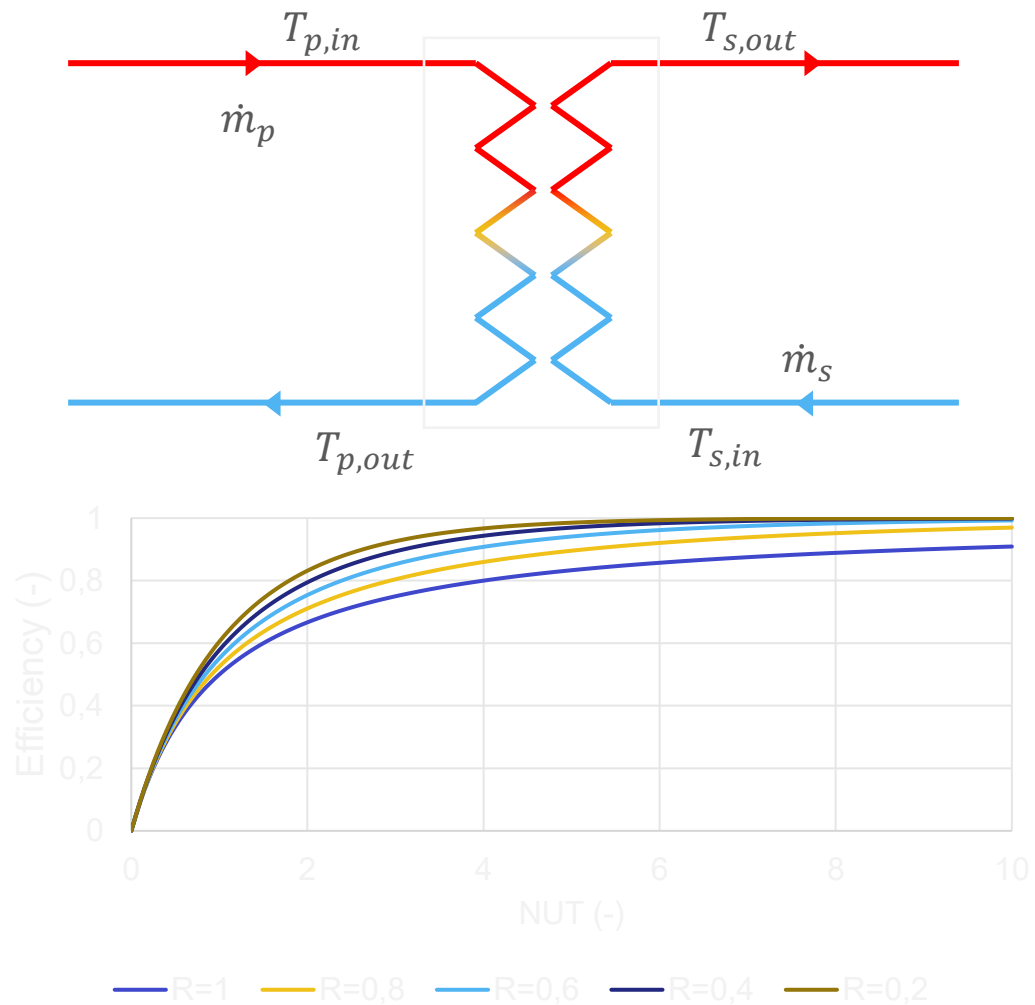

$$\dot{Q} = UA \Delta TLM = UA \frac{T_a - T_b}{\ln(T_a/T_b)}$$

$$T_a = \max(T_{p,in} - T_{s,out}; T_{p,out} - T_{s,in})$$

$$T_b = \min(T_{p,in} - T_{s,out}; T_{p,out} - T_{s,in})$$

$$R = \frac{\min(Cp \dot{m}_p ; Cp \dot{m}_s)}{\max(Cp \dot{m}_p ; Cp \dot{m}_s)} \quad NUT = \frac{UA}{\min(Cp \dot{m}_p ; Cp \dot{m}_s)}$$

$$E = \frac{1 - \exp((R - 1)NUT)}{1 - R \exp((R - 1)NUT)} \quad \text{For a counterflow HEX}$$

Increasing the HEX area at constant NUT, lower the pinch and so increase the HEX and DHN efficiency. But the more the HEX is large the more it costs

2. Substation components

Control valve



From the heat generation plant

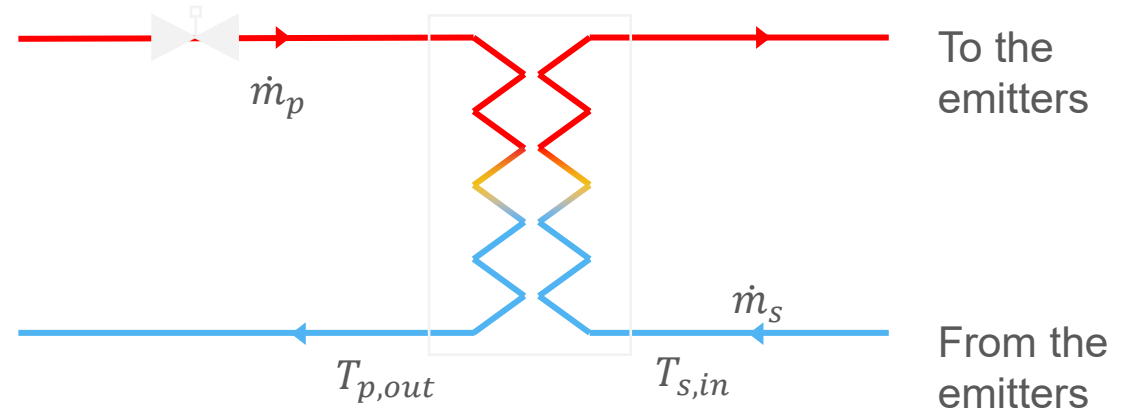

The control valve allows to control the mass flow rate through the primary side. It must be coupled with a sensor and a controller

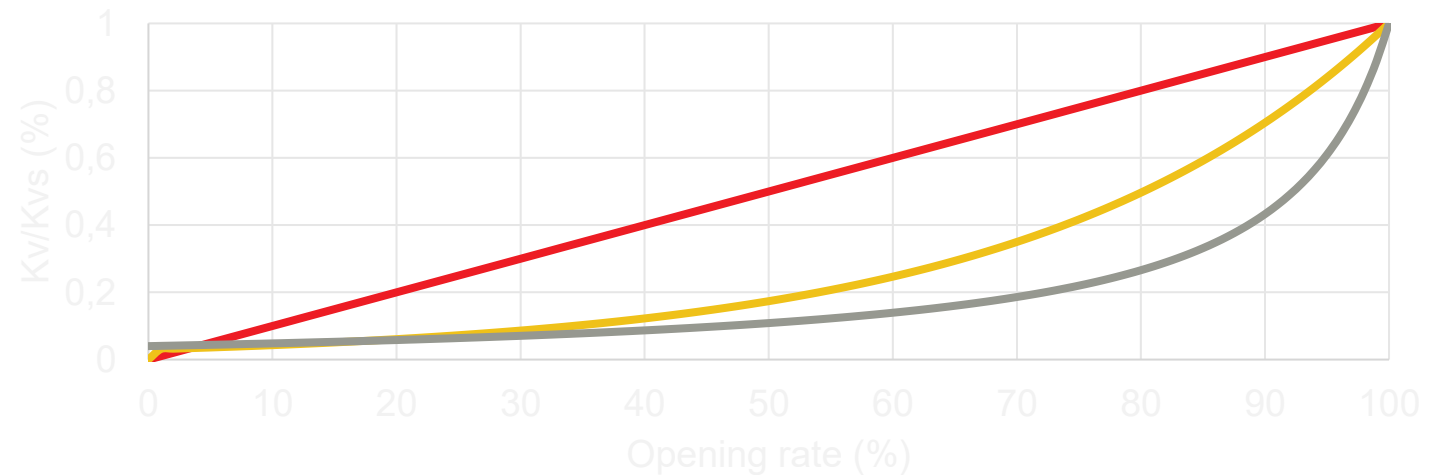

— Linear valve — Equal percentage valve — Equal percentage valve

2. Substation components

Sensors & controller



The controller compares the set point temperature to the measured one and sends an opening signal to the valve

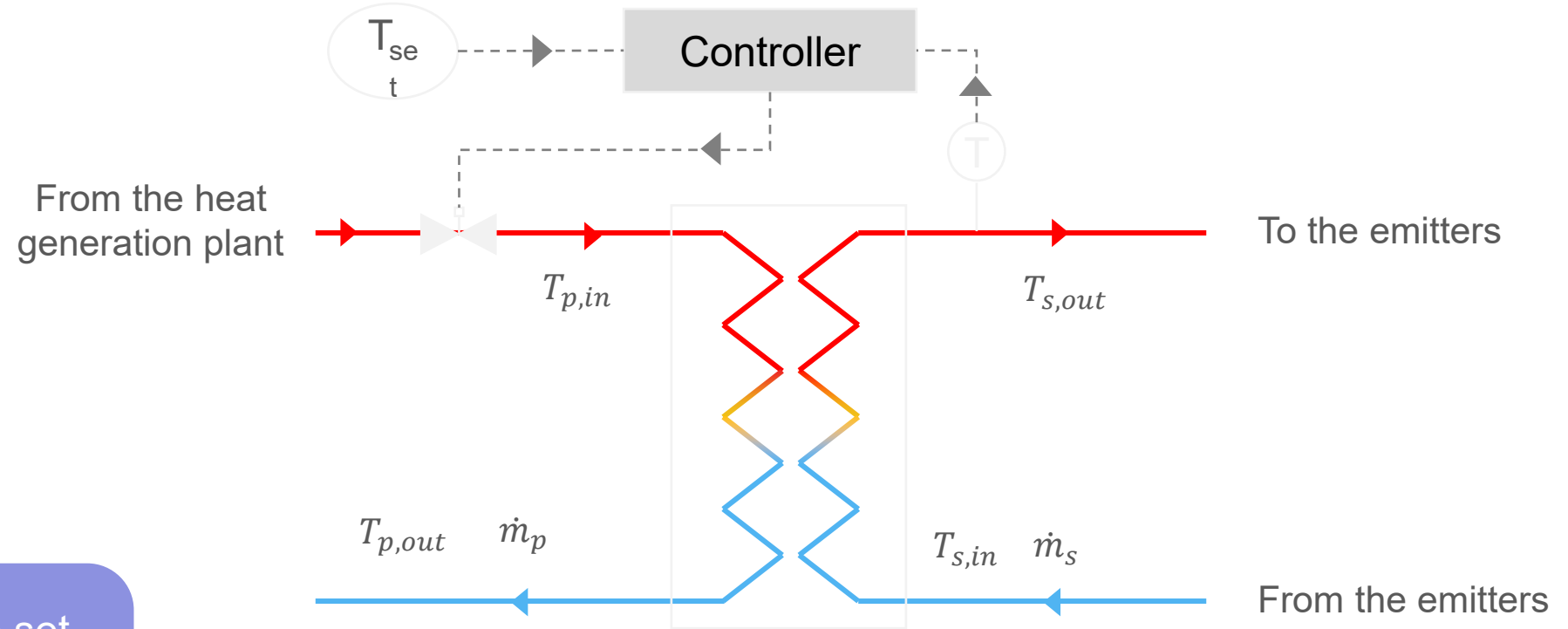

$$T_{set} = a T_{ext} + b \quad a = \frac{T_{emitters,max} - T_{ext,unheated+}}{T_{ext,min} - T_{ext,unheated}}$$

$$\text{For } T_{ext} = T_{ext,min} \Rightarrow T_{set} = T_{emitters,max}$$

$$\text{For } T_{ext} = T_{ext,unheated} \Rightarrow T_{set} = T_{ext,unheated+}$$

2. Substation components

Sensors & controller



The controller compares the set point temperature to the measured one and sends an opening signal to the valve

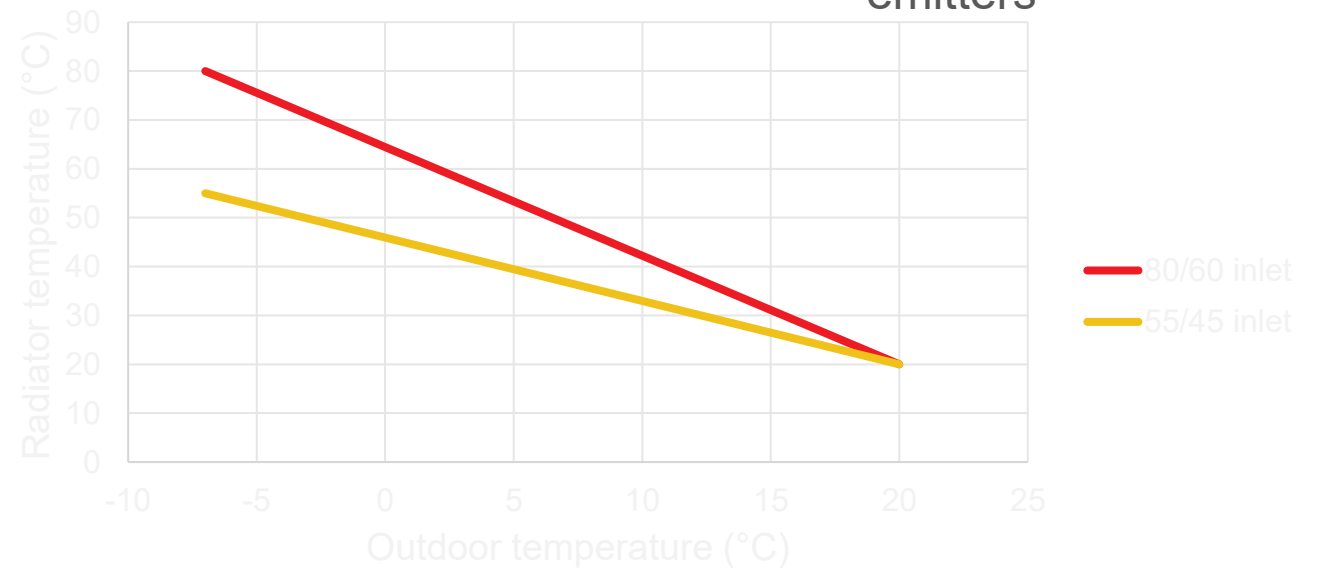
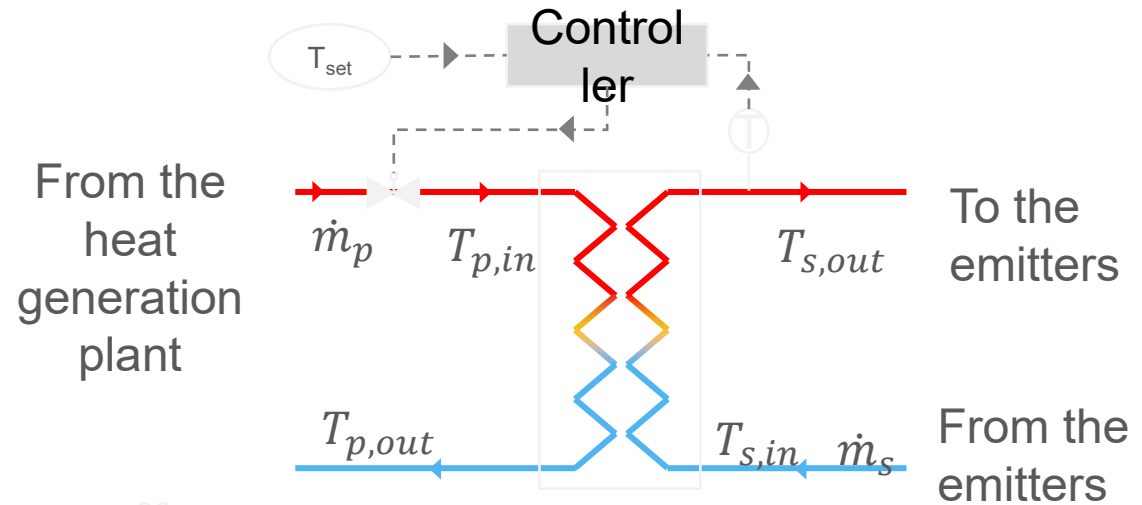

2. Substation components

Heat meters



The heat meter measures the supply and return temperatures and the flow rate at the primary side to calculate the energy consumed by the SST

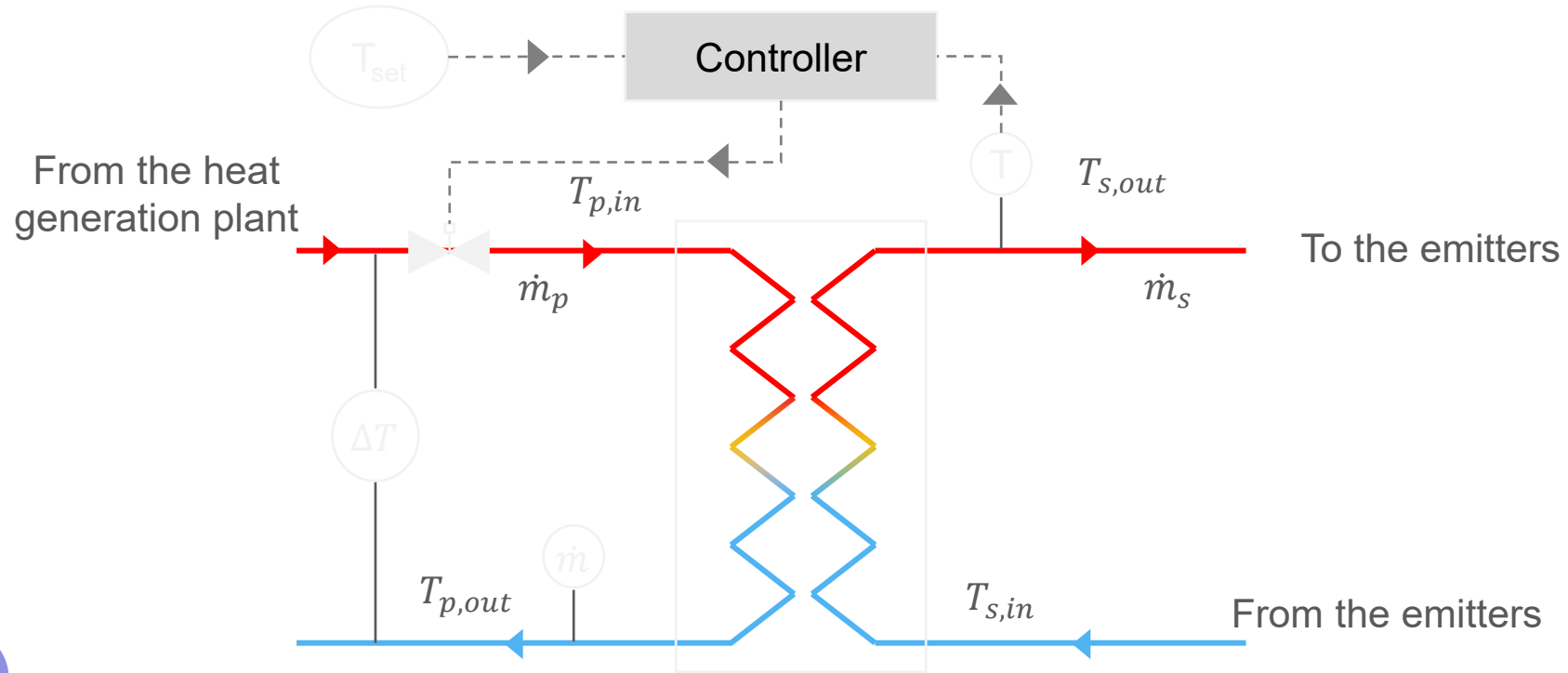

Uncertainty on flow rate

Norm EN 1434

$$E_f = \pm \left(2 + 0,02 \frac{q_{max}}{q} \right)$$

$$Q = \int_0^V \rho C_p \Delta T dV$$

$$E_t = \pm \left(0,5 + 3 \frac{\Delta T_{min}}{\Delta T} \right)$$

Uncertainty on temperature difference

2. Substation components

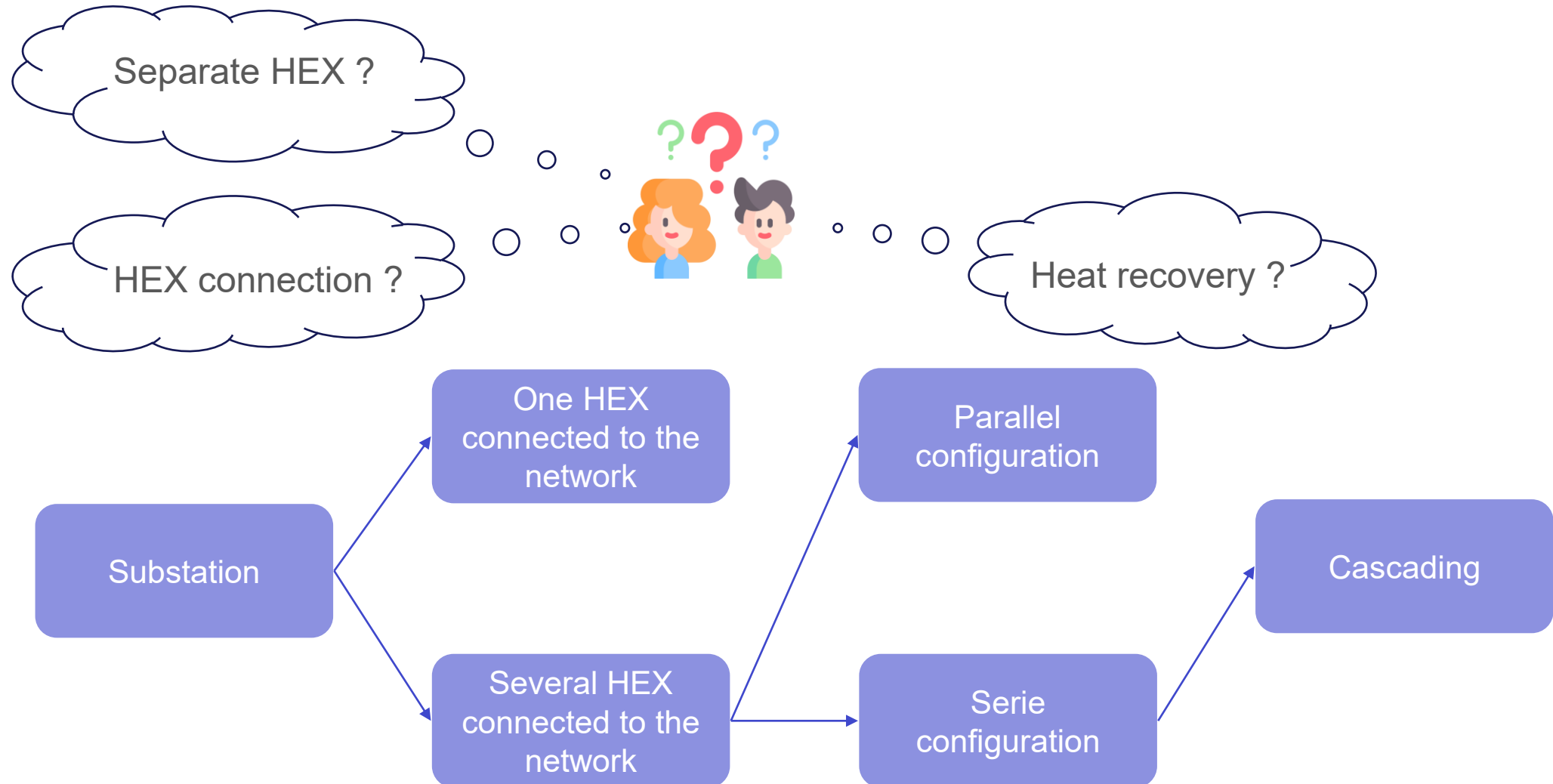

2. Substation components

One heat exchanger configuration

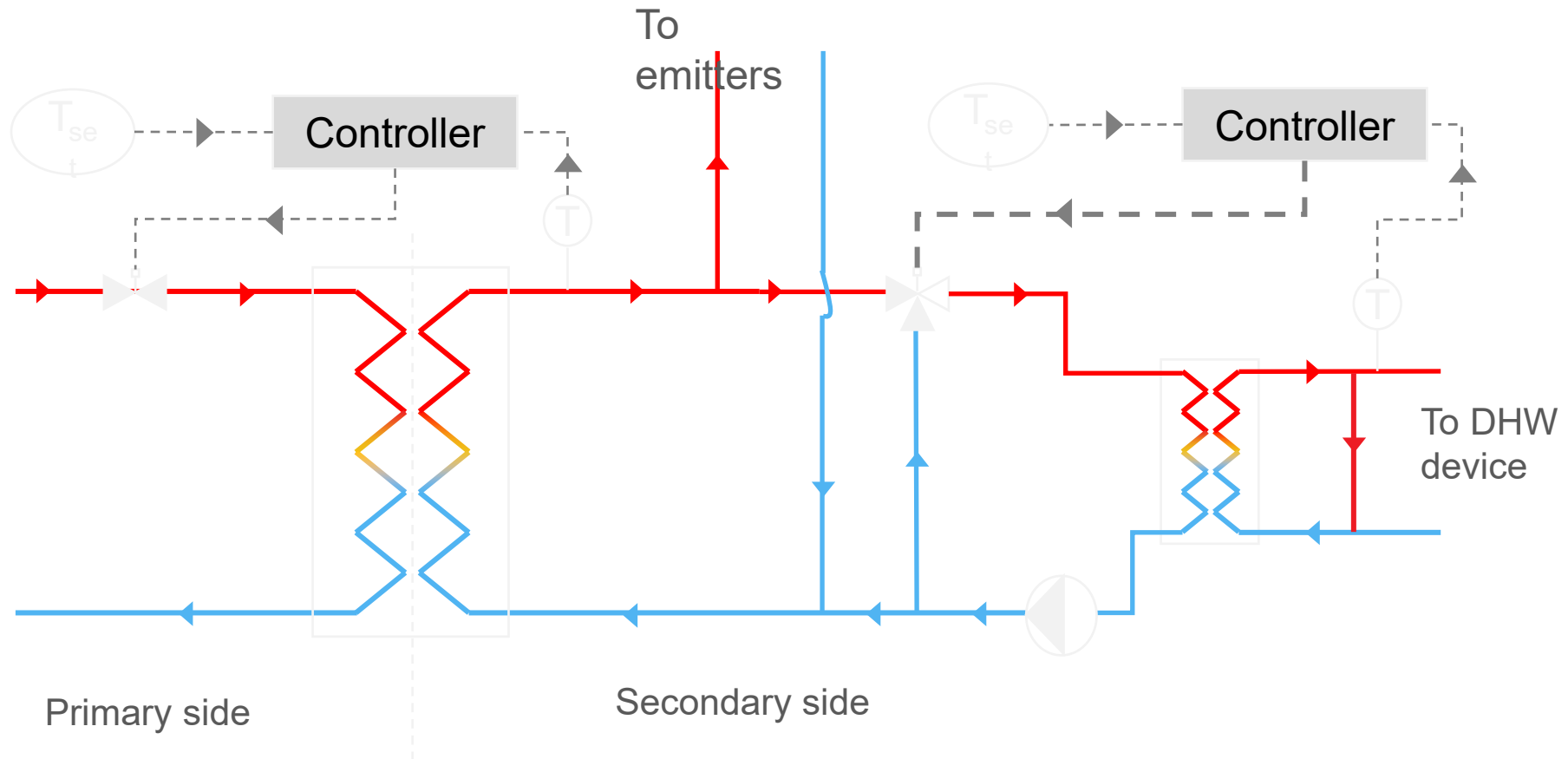

2. Substation components

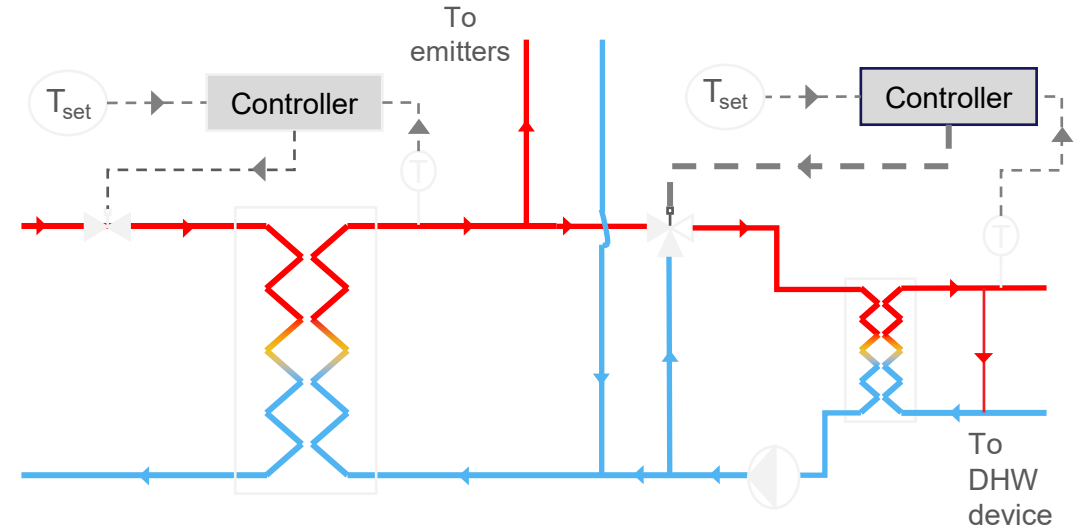
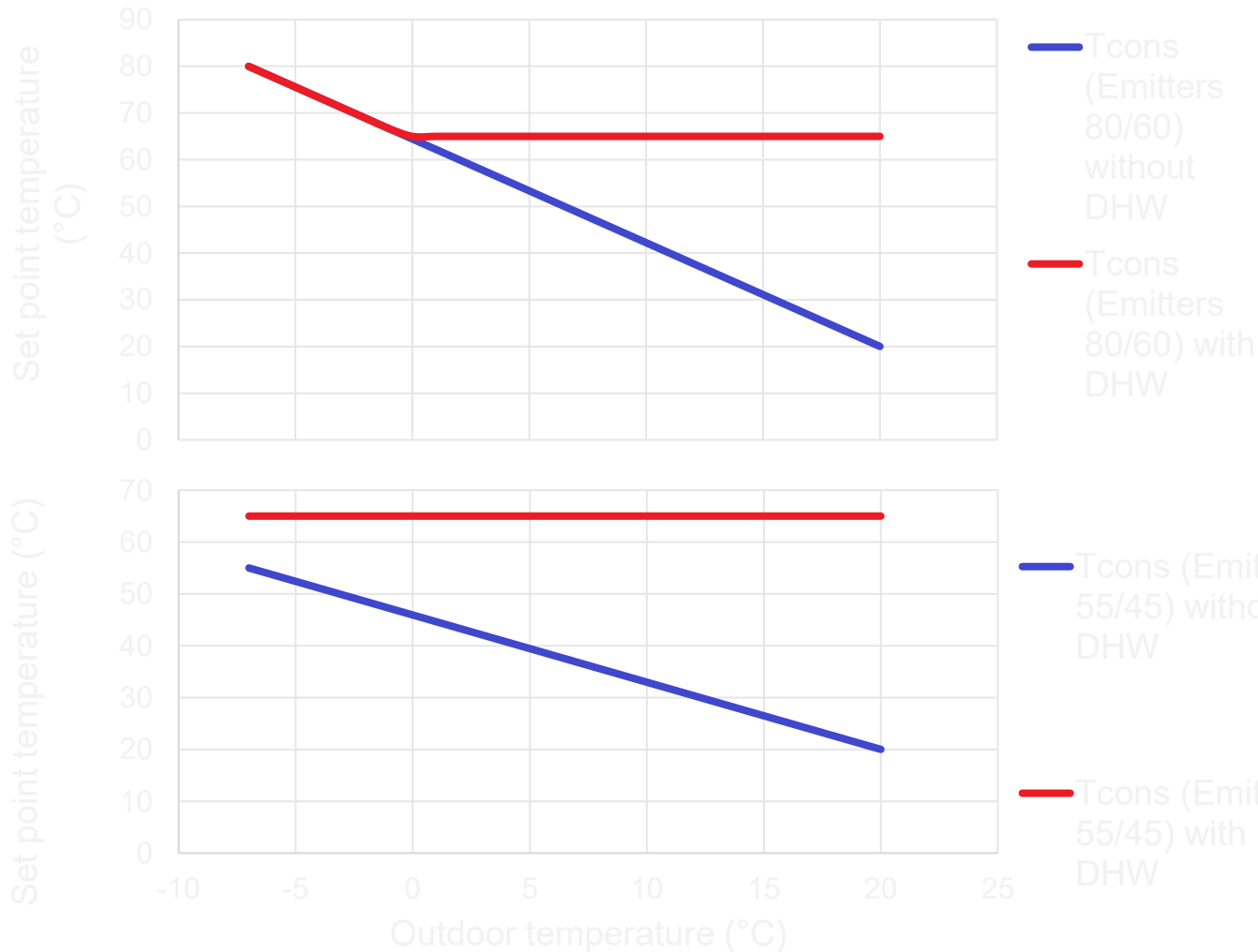

- Only one HEX connected directly to the networks
- Set point temperature must be superior to 60°C to supply DHW
- Secondary supply and return temperatures are high

2. Substation components

Parallel configuration

- Two HEX connected directly to the networks, one for the space heating and one for the DHW
- Set point temperature must be superior to 60°C to supply DHW
- Simple control and installation

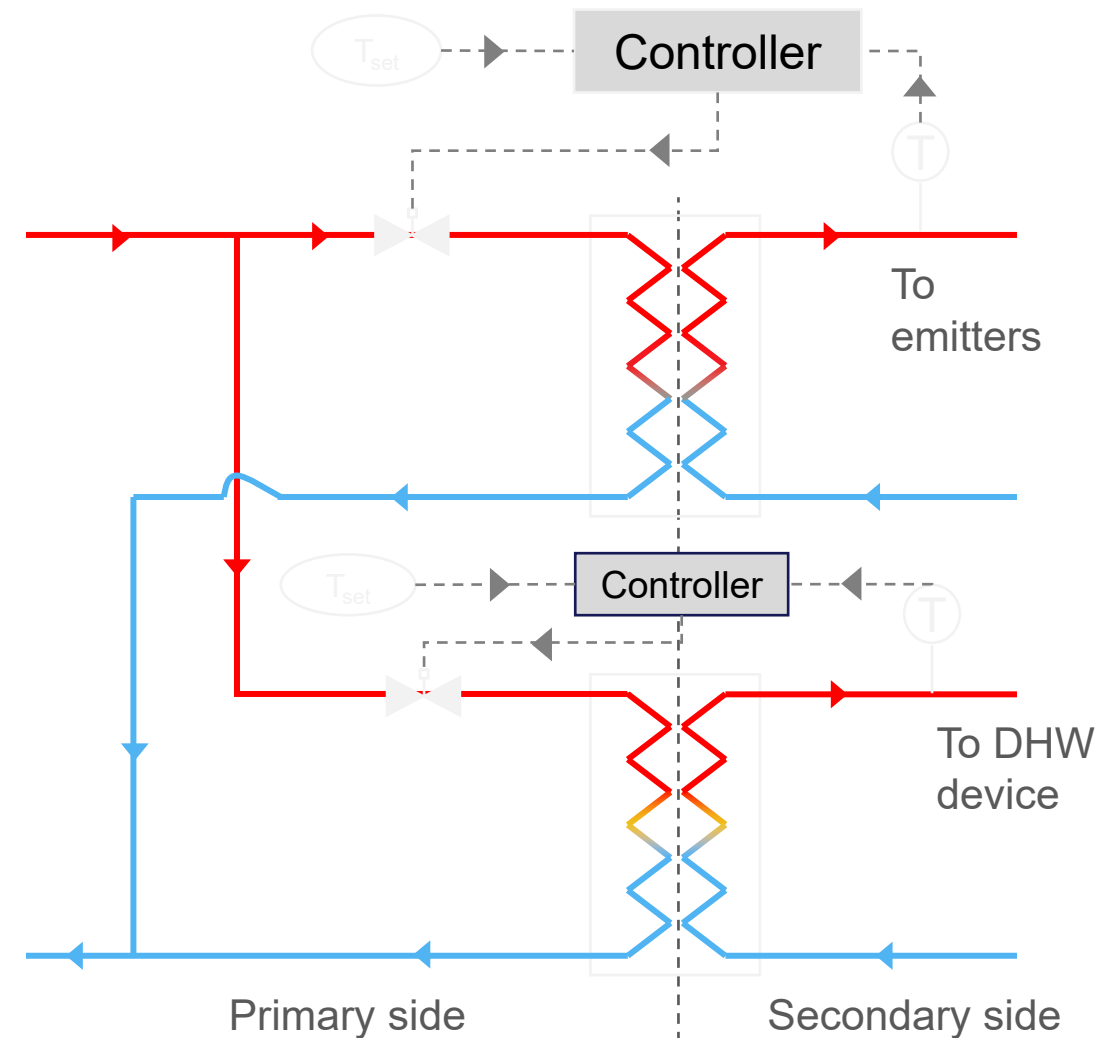
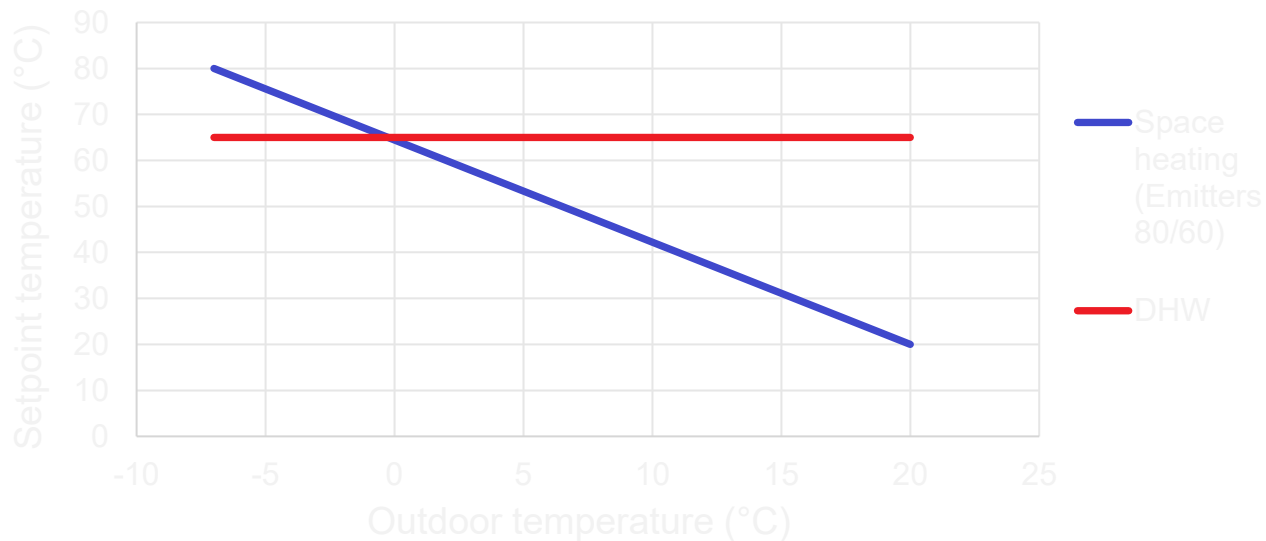

2. Substation components

Serie configuration

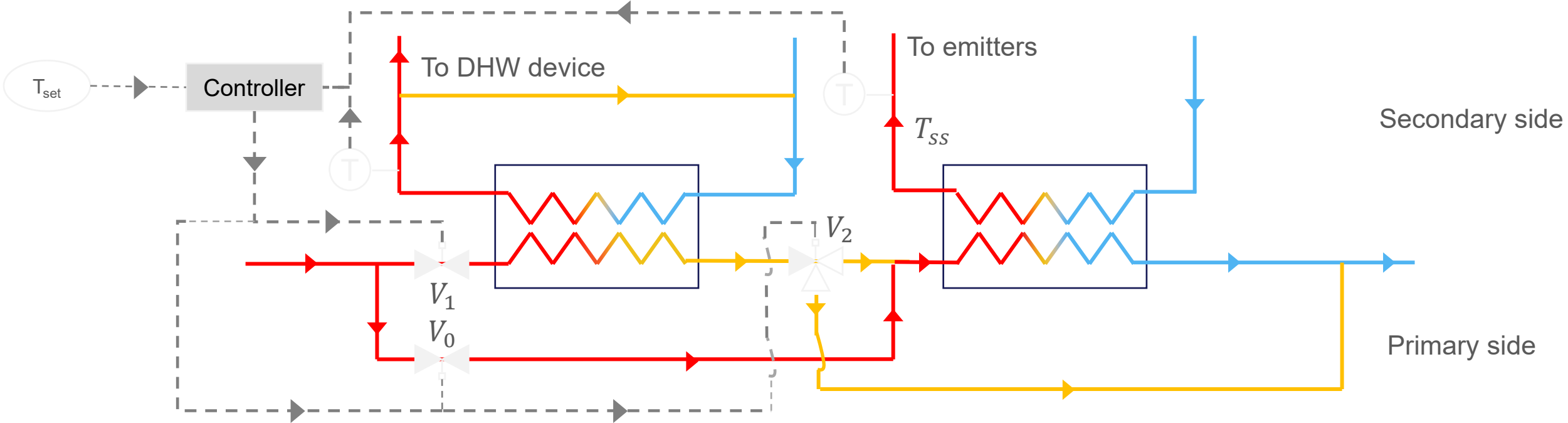

If $T_{ss} < T_{ss,set}$ firstly V_2 opens and after V_0 opens If $T_{ss} > T_{ss,set}$ firstly V_0 closed and after V_2 closed

2. Substation components

Serie configuration

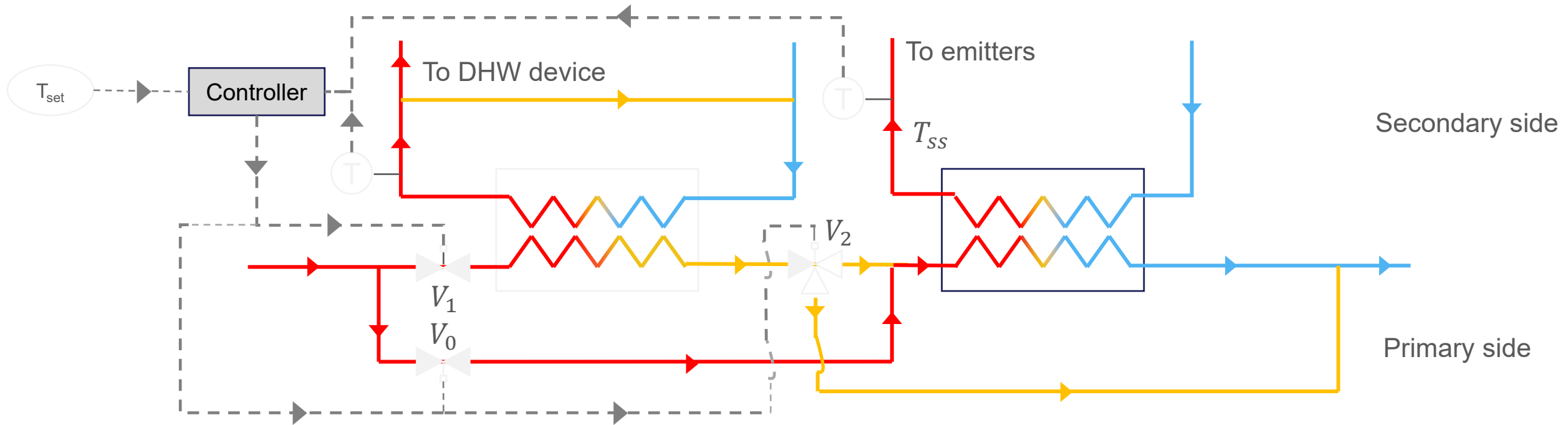

If $T_{ss} < T_{ss,set}$ firstly V_2 opens and after V_0 opens If $T_{ss} > T_{ss,set}$ firstly V_0 closed and after V_2 closed

2. Substation components

Serie configuration

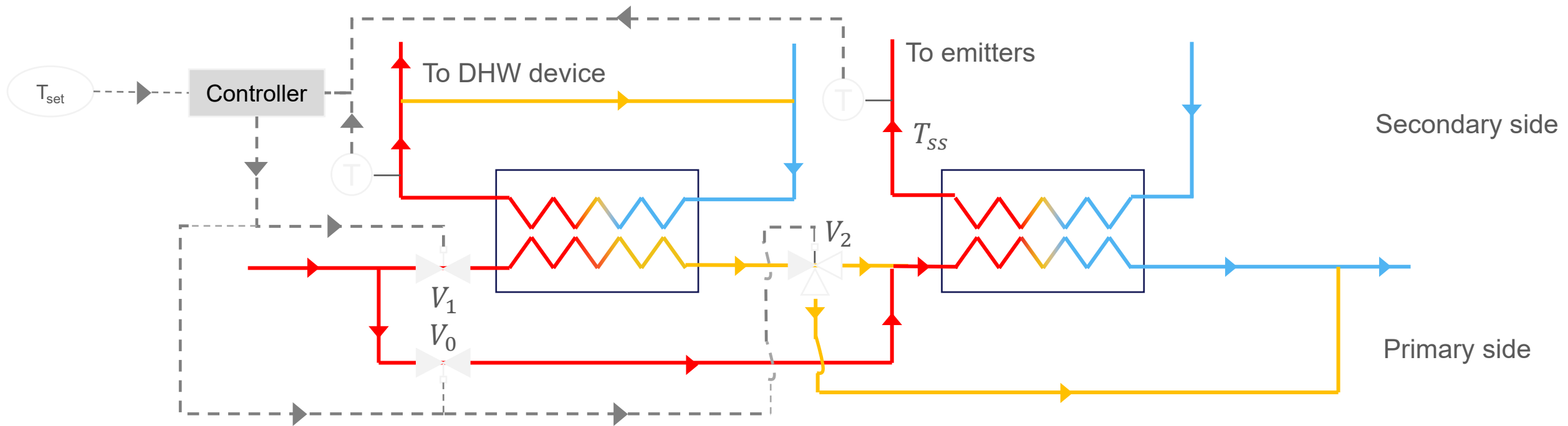

If $T_{ss} < T_{ss,set}$ firstly V_2 opens and after V_0 opens If $T_{ss} > T_{ss,set}$ firstly V_0 closed and after V_2 closed

2. Substation components

Series configuration

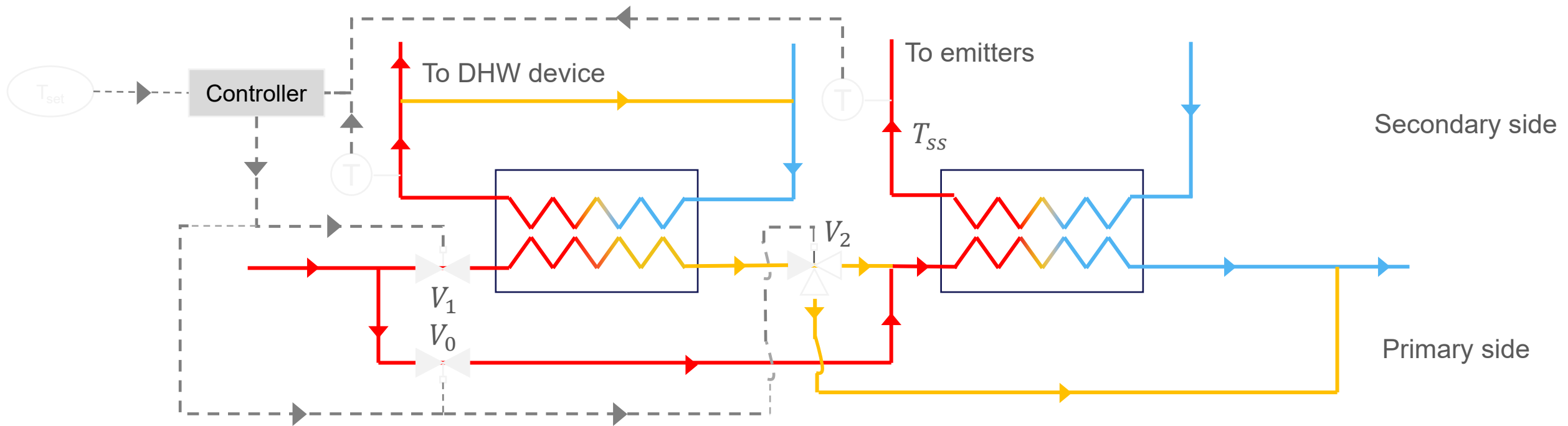

If $T_{ss} < T_{ss,set}$ firstly V_2 opens and after V_0 opens If $T_{ss} > T_{ss,set}$ firstly V_0 closed and after V_2 closed

2. Substation components

Series configuration

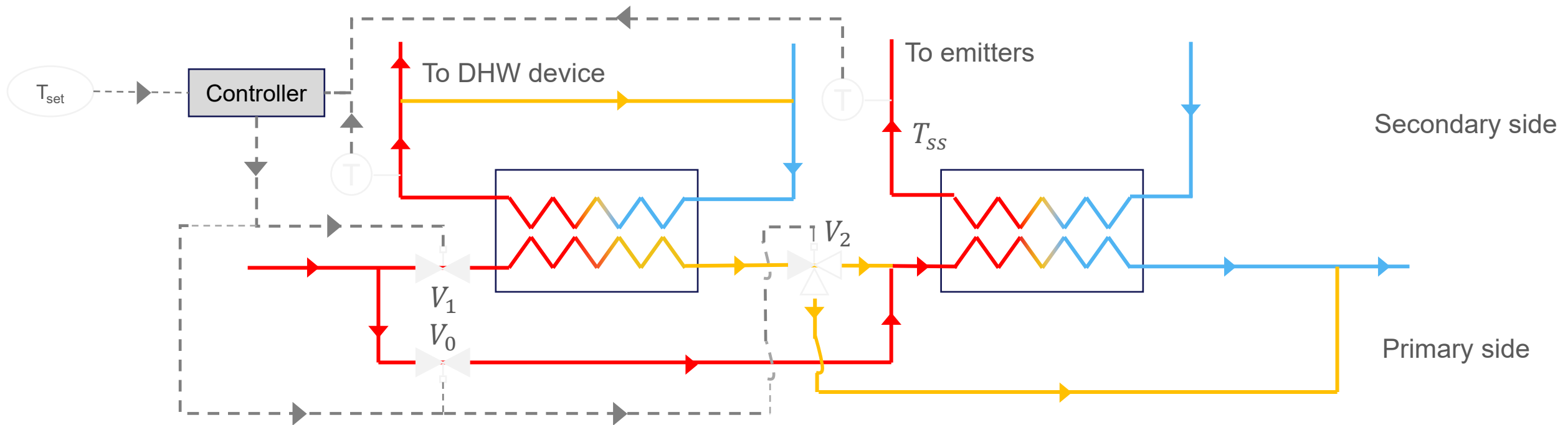

If there is only a space heating demand $\rightarrow V_1$ is fully closed $\Rightarrow V_0$ opens

2. Substation components

Series configuration

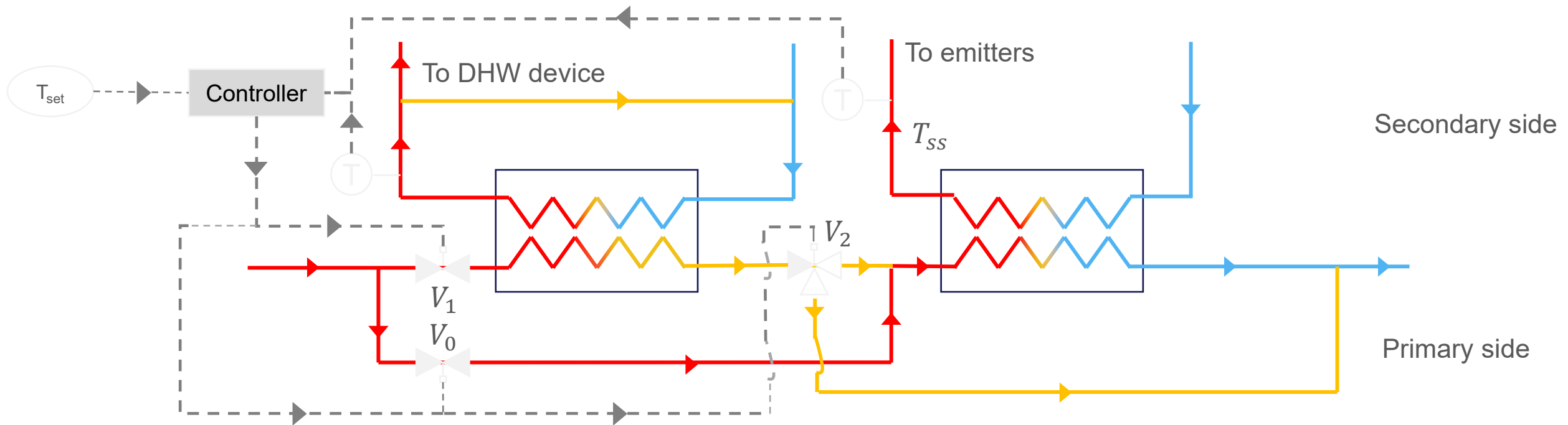

If there is only a DHW demand $\rightarrow V_0$ & V_2 is fully closed $\Rightarrow V_1$ opens

2. Substation components

Serie configuration

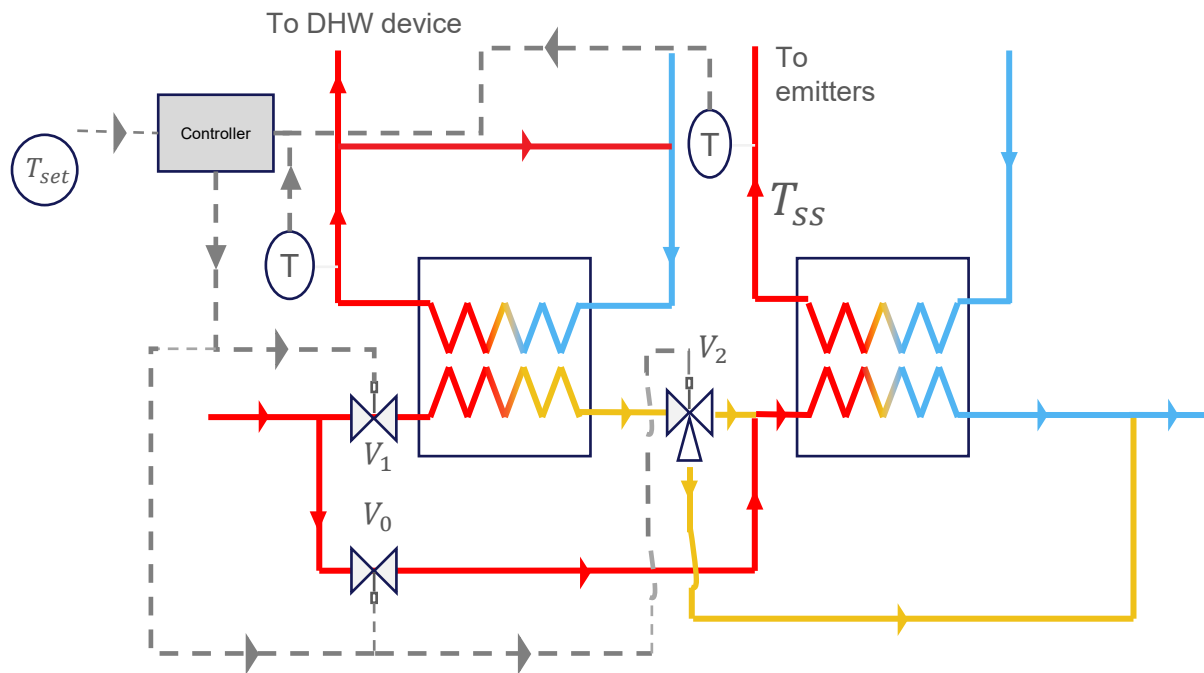

- Two HEX connected directly to the network, one for the space heating and one for the DHW
- Set point temperature must be superior to 60°C to supply DHW
- More complex control
- Not common, mostly used when space heating emitters operate at low temperature (ie 55/45 or less)

2. Substation components

2-stage configuration

- Two HEX connected directly to the supply networks, one for the space heating and one for the DHW
- A third HEX for the preheating of the DHW using the primary return of the space heating and DHW HEX
- Set point temperature must be superior to 60°C to supply DHW
- Easy control
- More efficient than the parallel configuration but more expensive.
- Parallel configuration is often preferred

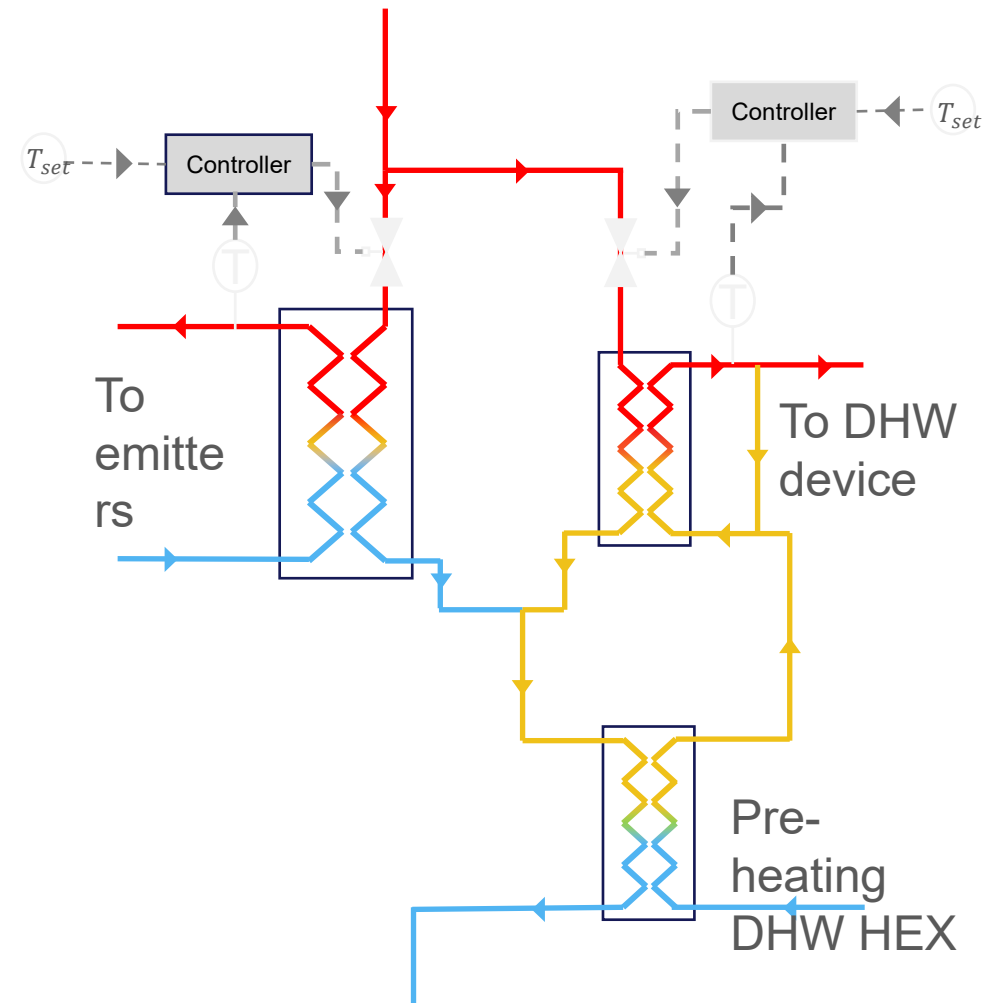

3. Conclusion

What is the objective of the different configurations?

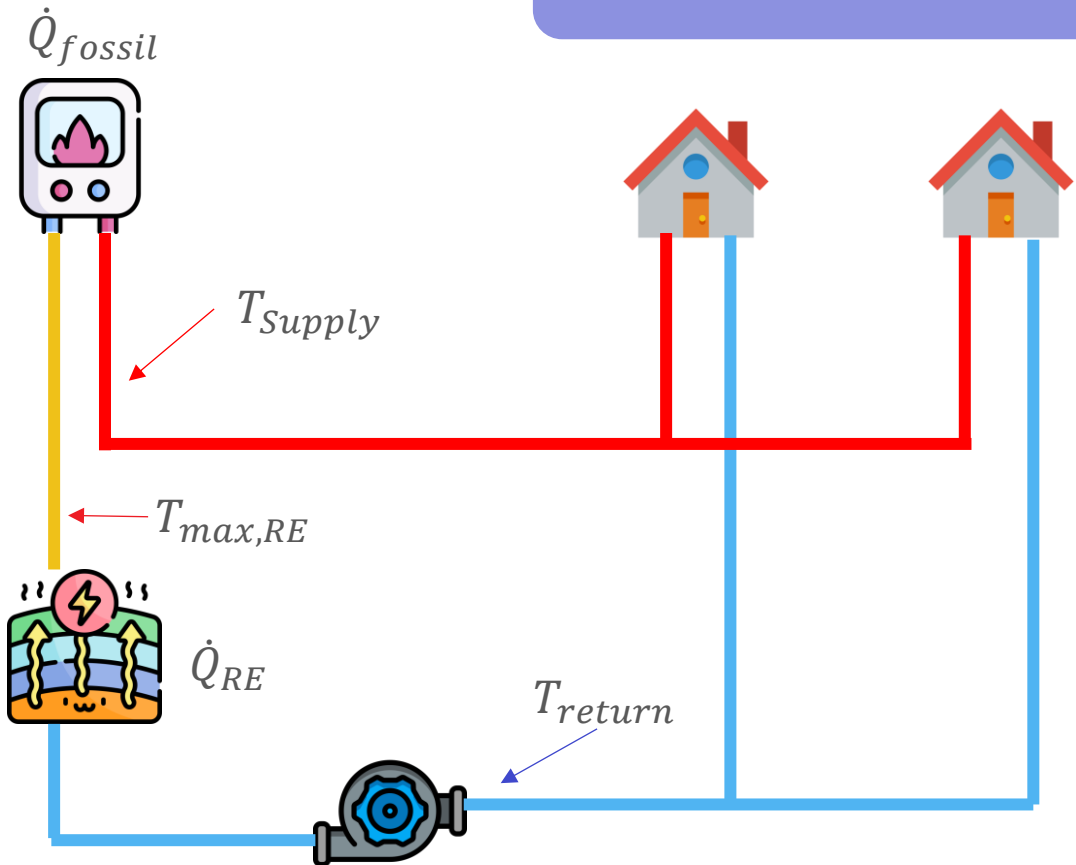

Reducing the return temperature

$$\dot{Q} = \dot{Q}_{fossil} + \dot{Q}_{RE}$$
$$\dot{Q} = \dot{m} C_p (T_{supply} - T_{max,RE} + T_{max,RE} - T_{return})$$

This also allows to:

- ➔ Reducing the thermal losses through the pipes
- ➔ Reducing the pump consumption
- ➔ Increasing the RE heat production from low temperature energy sources

3. Conclusion

What is the objective of the different configurations?



Reducing the return temperature

$$\dot{Q} = \dot{Q}_{fossil} + \dot{Q}_{RE}$$

$$\dot{Q} = \dot{m} C_p (T_{Supply} - T_{max,RE} + T_{max,RE} - T_{return})$$

This also allows to:

- ➔ Reducing the thermal losses through the pipes
- ➔ Reducing the pump consumption
- ➔ Increasing the RE heat production from low temperature energy sources

	Performance	Price	Complexity
1 HEX	--	+	0
Parallel	+	+	+
Serie	-	-	--
Cascading (2 stage)	++	--	-



Thank you!

Module 2.6 - Primary network

SHaKE – Sharing Heat and Knowledge on Energy Communities

<https://www.shakeproject-dhc.eu/>

Developed by Mines Paris – PSL
Antoine Fabre | antoine.fabre@minesparis.psl.eu
Pascal Stabat | pascal.stabat@minesparis.psl.eu



Co-funded by
the European Union

