

# Module 2.1 – Introduction Heat and Cold Energy Demands of Buildings

SHaKE – Sharing Heat and Knowledge on Energy  
Communities  
Erasmus+ KA220-HED Cooperation Partnerships in Higher  
Education  
Developing institution: Mines Paris – PSL  
Author: Dr. Antoine Fabre  
Date: March 2026  
Version 1.0



**SHaKE**

Sharing Knowledge on Energy Communities



# 1.Key figures

Primary energy consumption by sector in UE 2021

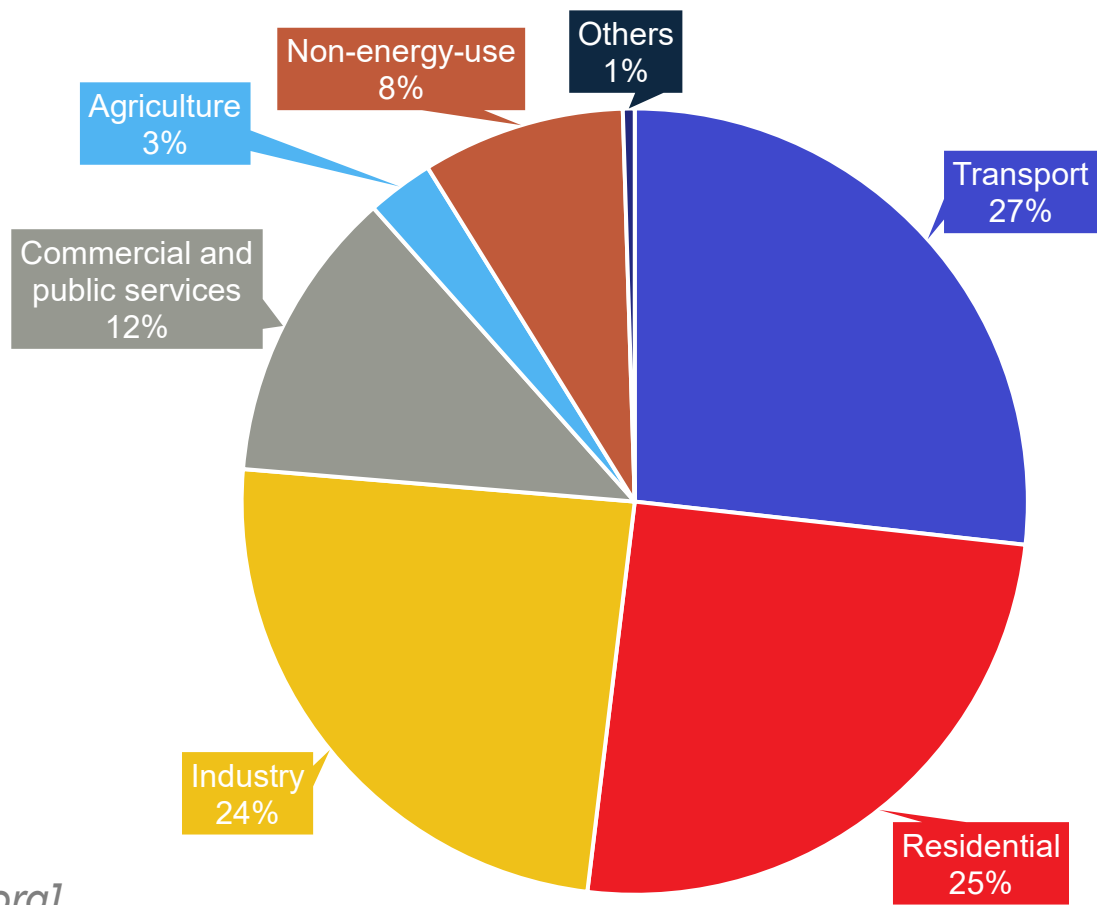

[IEA.org]

- The residential sector represents 25% of the primary energy consumption in the EU
- The primary energy consumption of the residential sector is 4124 TWh



# 1.Key figures

Final energy consumption by use in residential sector EU 2022

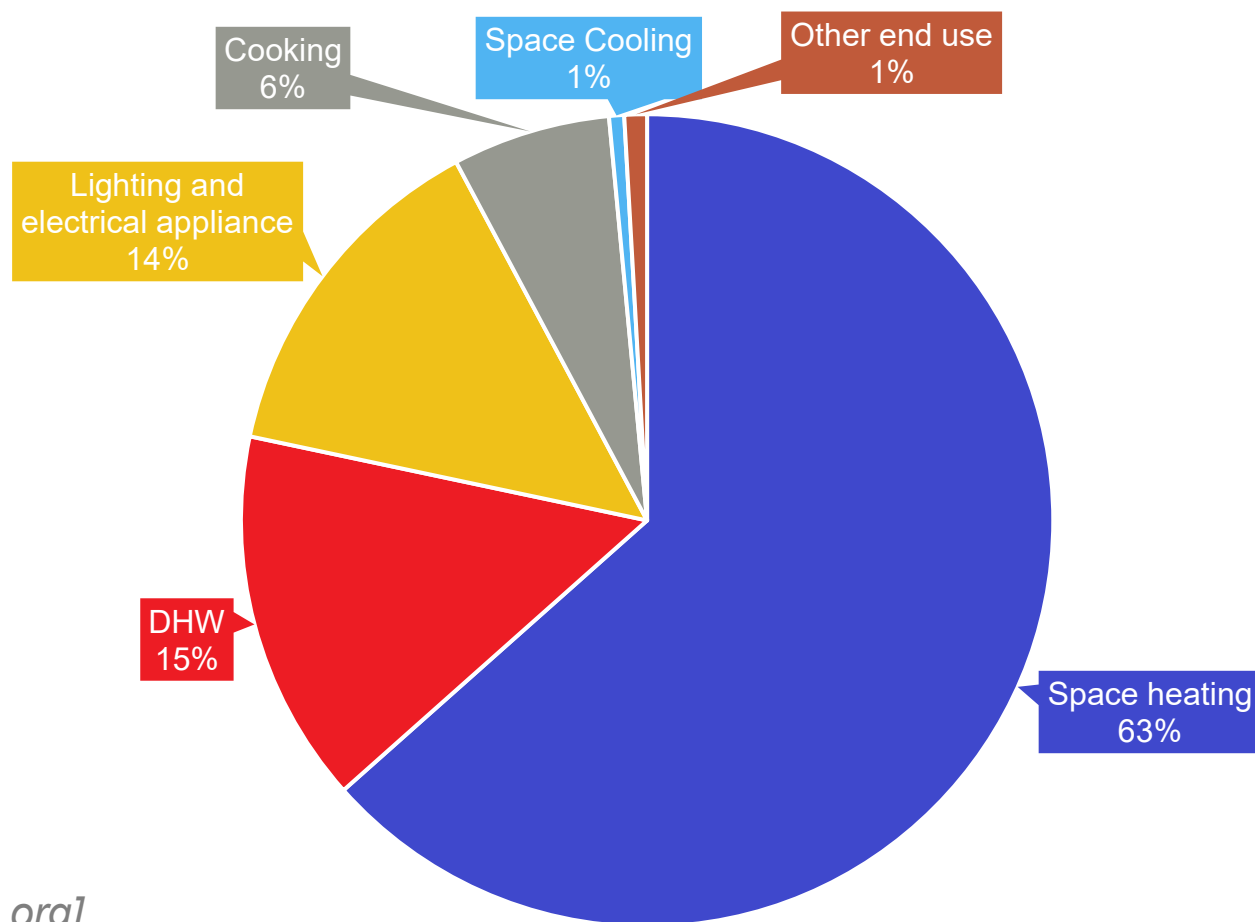

- The share of DHW and space heating final energy consumption in residential sector in EU represents 78%
- The space heating and DHW consumption is 2208 TWh



# 1.Key figures

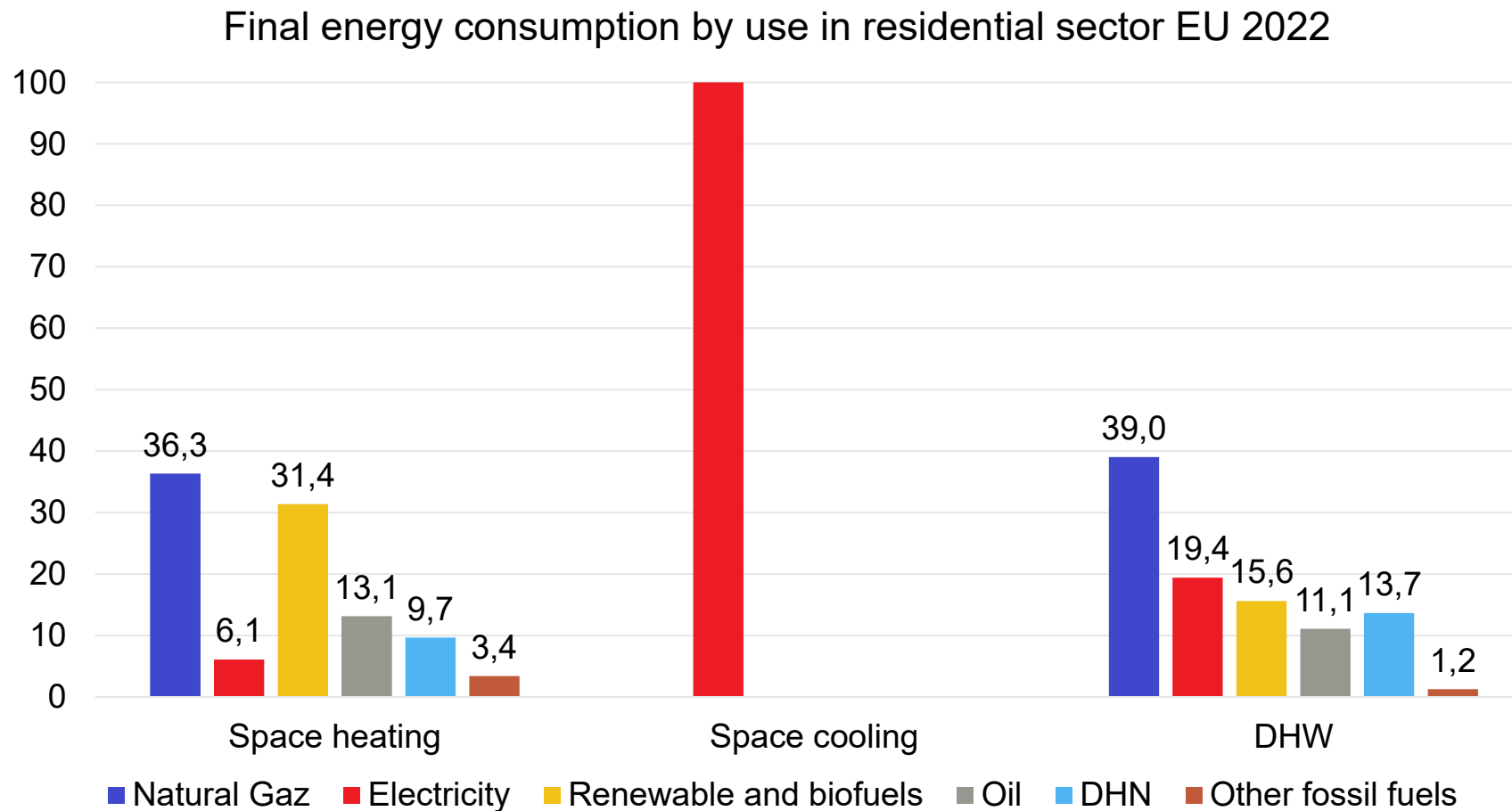

## 2. Description of the heat losses

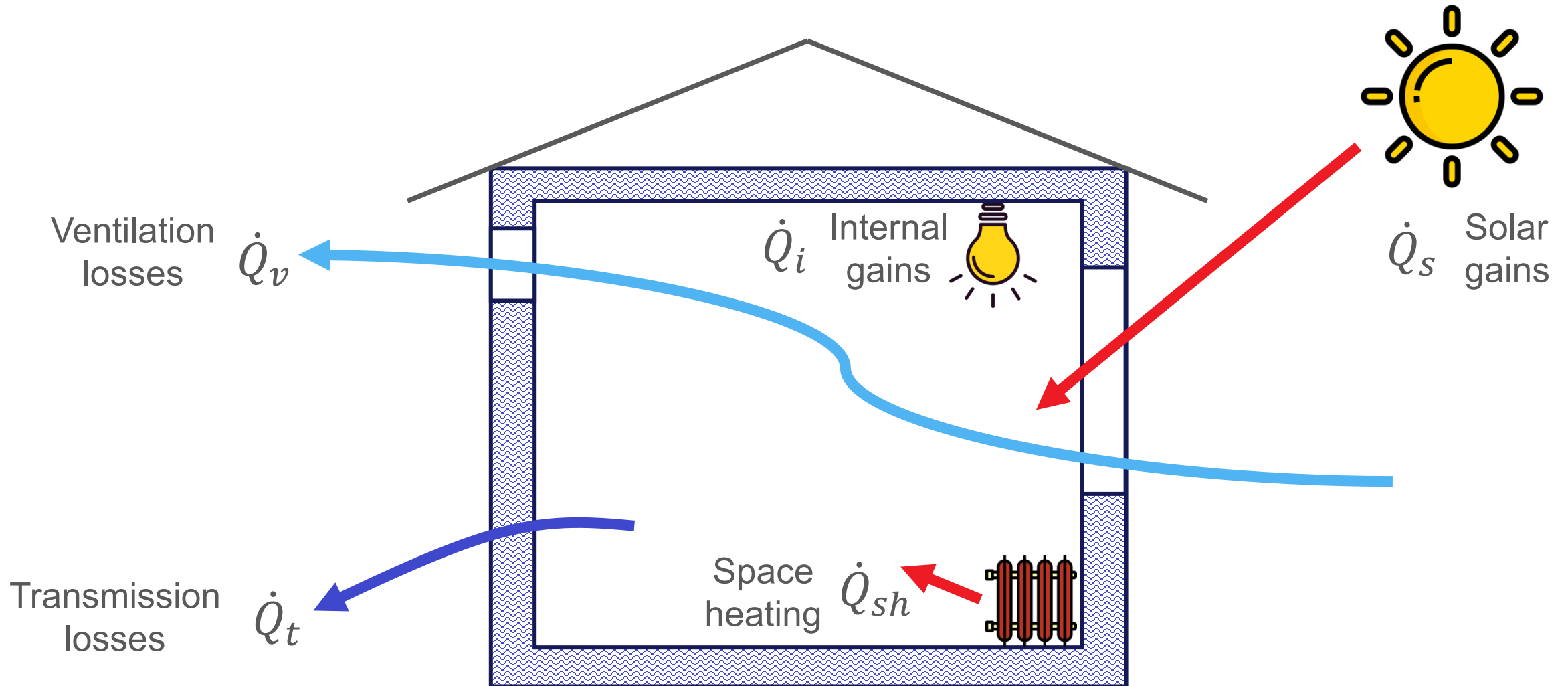

## 2. Description of the heat losses

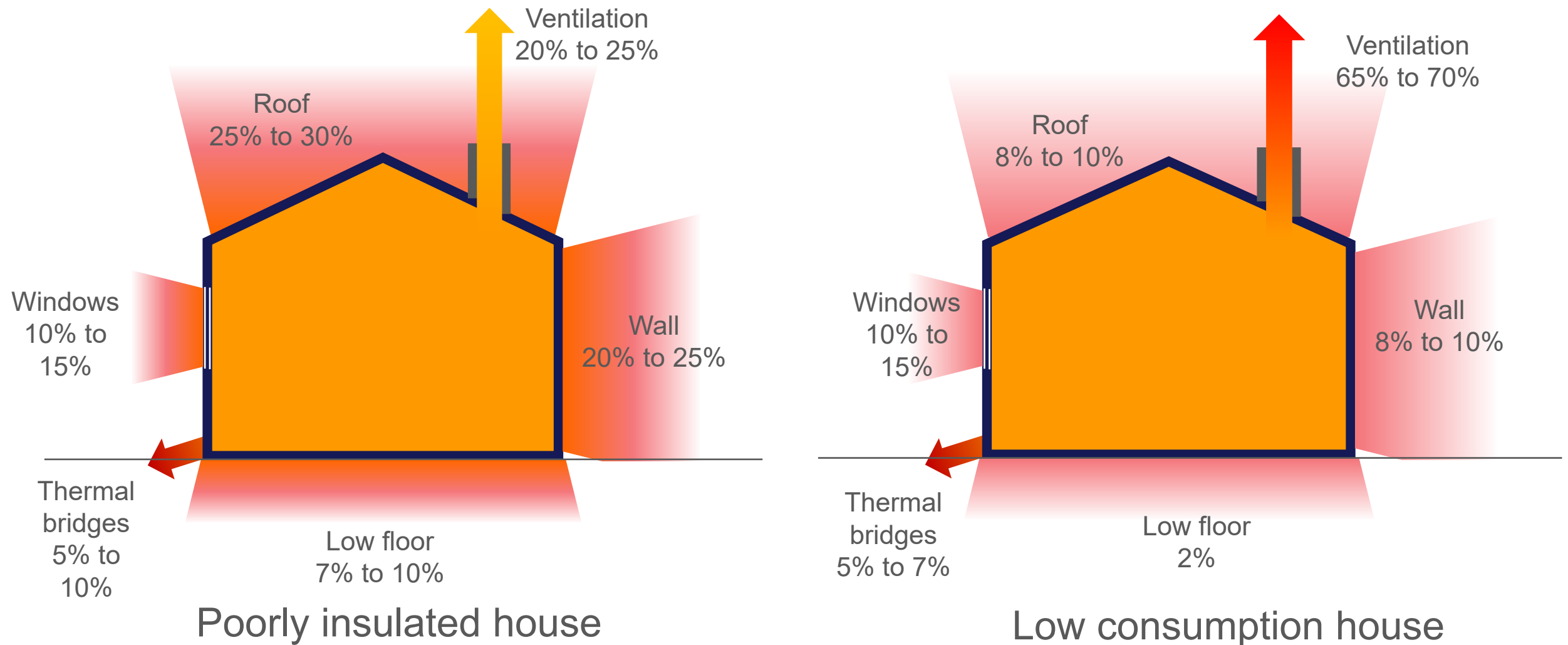

# 2. Description of the heat losses

$$\dot{Q}_{sh} = \dot{Q}_t + \dot{Q}_v - [\dot{Q}_s + \dot{Q}_i]$$

Space heating

Transmission losses

Ventilation losses

Solar gains

Internal gains

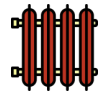

Radiators



Walls



Mechanical ventilation



Lights



Fan-coil unit

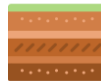

Ground



Infiltrations



Occupants



Radiant floor



Windows



Electric appliances



Thermal bridges



Non heated spaces

# 2. Description of the heat losses

$$\dot{Q}_{sh} = \dot{Q}_t + \dot{Q}_v - [\dot{Q}_s + \dot{Q}_i]$$

Space heating

Transmission losses

Ventilation losses

Solar gains

Internal gains

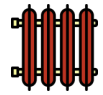

Radiators



Walls



Mechanical ventilation



Lights



Fan-coil unit

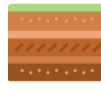

Ground



Infiltrations



Occupants



Radiant floor



Windows



Electric appliances



Thermal bridges



Non heated spaces

## 2. Description of the heat losses

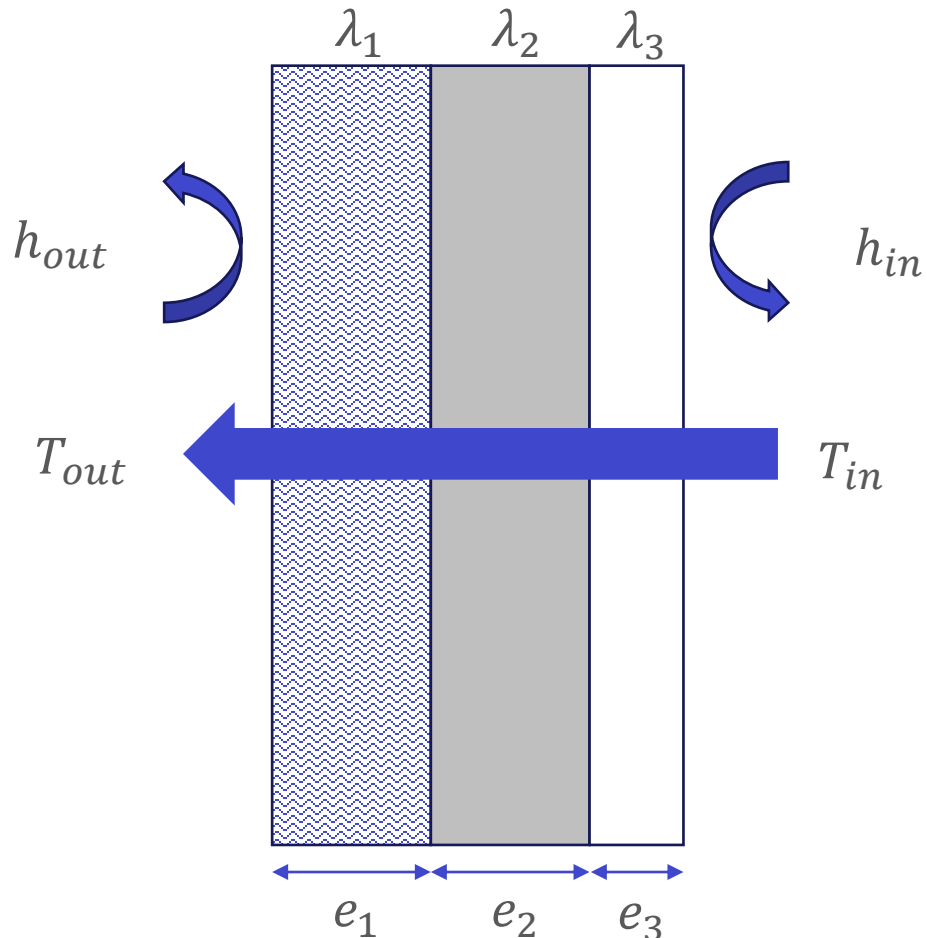

Thermal transfer due to transmission through the walls, the windows, the floor or the roof :

$$\dot{Q}_t = U A_t (T_{in} - T_{out}) \quad [W]$$

Thermal transfer coefficient [W/K]

Indoor temperature [K] or [°C]

Outdoor temperature [K] or [°C]

## 2. Description of the heat losses

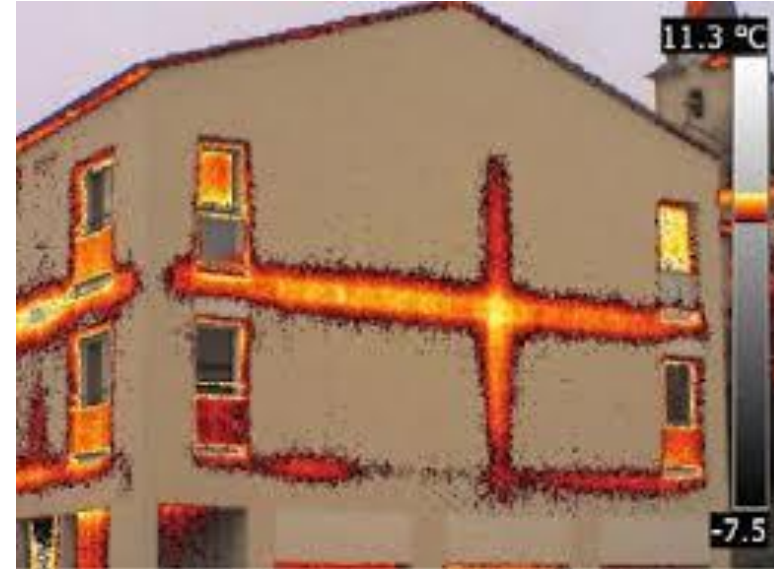
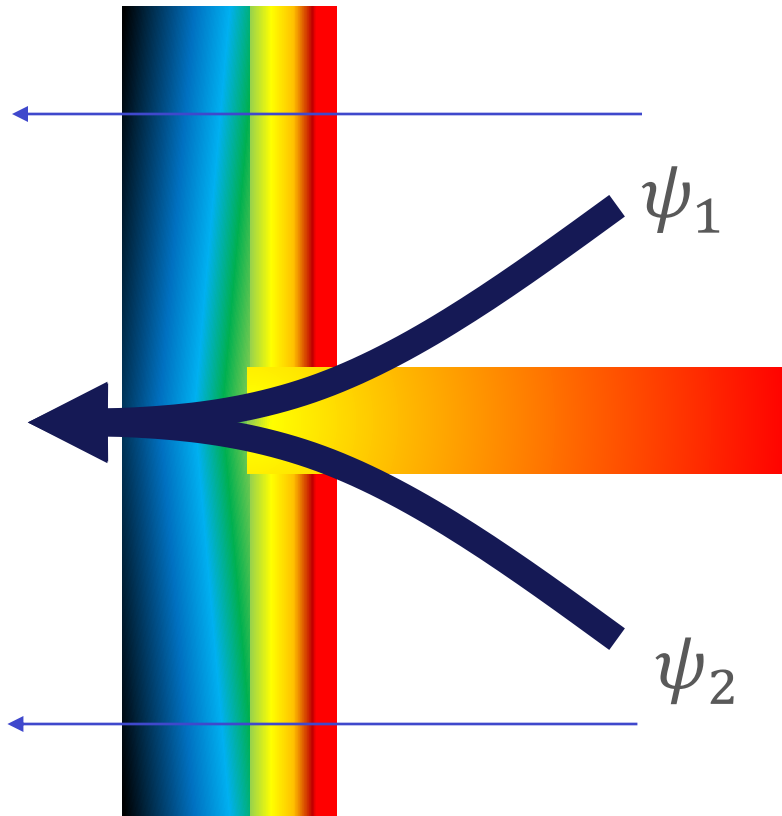

$$\dot{Q}_{tb} = \sum_i \psi_i L_i (T_{in} - T_{out})$$

Thermal bridge  
coefficient [W/m.K]

Thermal bridge length [m]

# 2. Description of the heat losses

$$\dot{Q}_{sh} = \dot{Q}_t + \dot{Q}_v - [\dot{Q}_s + \dot{Q}_i]$$

Space heating

Transmission losses

Ventilation losses

Solar gains

Internal gains

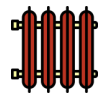

Radiators



Walls



Mechanical ventilation



Lights



Fan-coil unit

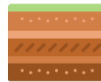

Ground



Infiltrations



Occupants



Radiant floor



Windows



Electric appliances



Thermal bridges



Non heated spaces

## 2. Description of the heat losses

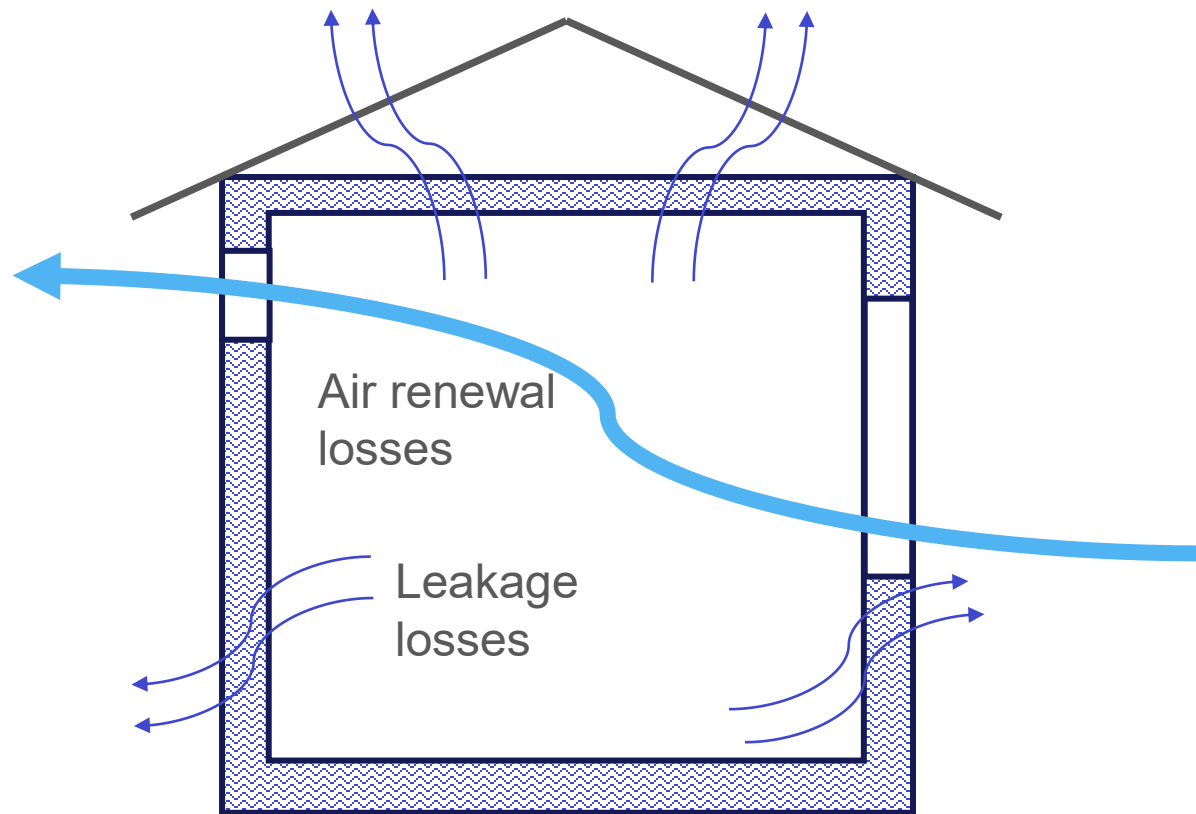

$$\dot{Q}_v = \rho C_p \dot{V}_{air\ renewal} (T_{int} - T_{out})$$

Specific heat [kJ/kg/K] →  $C_p$   
Indoor temperature [K] or [°C] →  $T_{int}$   
Density [kg/m<sup>3</sup>] →  $\rho$   
Air flow rate [m<sup>3</sup>/s] →  $\dot{V}_{air\ renewal}$   
Outdoor temperature [K] or [°C] →  $T_{out}$

# 2. Description of the heat losses

$$\dot{Q}_{sh} = \dot{Q}_t + \dot{Q}_v - [\dot{Q}_s + \dot{Q}_i]$$

Space heating

Transmission losses

Ventilation losses

Solar gains

Internal gains

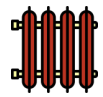

Radiators



Walls



Mechanical ventilation



Lights



Fan-coil unit

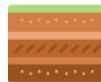

Ground



Infiltrations



Occupants



Radiant floor



Windows



Electric appliances



Thermal bridges



Non heated spaces

## 2. Description of the heat losses

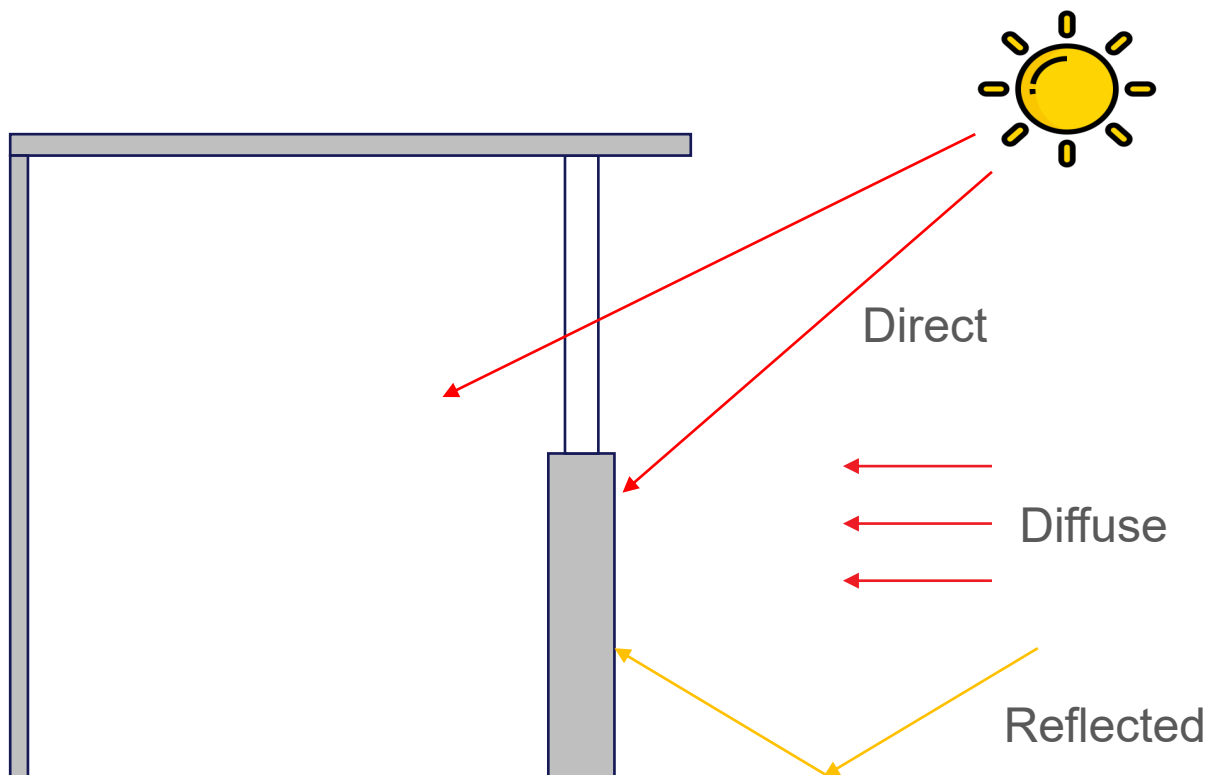

$$\dot{Q}_s = \alpha S (E_{dir} + E_{ref} + E_{dif})$$

Area [m<sup>2</sup>]

Reflected insolation [W/m<sup>2</sup>]

Absorptivity [-]

Direct insolation [W/m<sup>2</sup>]

Diffuse insolation [W/m<sup>2</sup>]

# 2. Description of the heat losses

$$\dot{Q}_{sh} = \dot{Q}_t + \dot{Q}_v - [\dot{Q}_s + \dot{Q}_i]$$

Space heating

Transmission losses

Ventilation losses

Solar gains

Internal gains

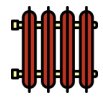

Radiators



Walls



Mechanical ventilation



Lights



Fan-coil unit

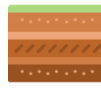

Ground



Infiltrations



Occupants



Radiant floor



Windows



Electric appliances



Thermal bridges



Non heated spaces

# 2. Description of the heat losses



Occupants



	Individual house	Multi-family house	Office	School	Restaurant
Occupation (m <sup>2</sup> /pers)	40	60	20	10	5
Presence (h/day)	12	12	6	4	3
Power (W/pers)	70	70	80	70	100

## 2. Description of the heat losses



### Lights



	Individual house	Multi-family house	Office	School	Restaurant
Power (kWh/m <sup>2</sup> /year)	27,8	22,2	22,2	11,1	33,3
Corrective factor $f_e$	0,7	0,7	0,9	0,9	0,7

# 2. Description of the heat losses

$$\dot{Q}_{sh} = \dot{Q}_t + \dot{Q}_v - [\dot{Q}_s + \dot{Q}_i]$$

Space heating

Transmission losses

Ventilation losses

Solar gains

Internal gains

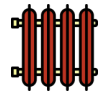

Radiators



Walls



Mechanical ventilation

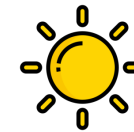

Lights



Fan-coil unit

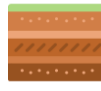

Ground



Infiltrations



Occupants



Radiant floor



Windows



Electric appliances



Thermal bridges



Non heated spaces

# 3. Description of the DHW needs

Final energy consumption by use in residential sector EU 2022

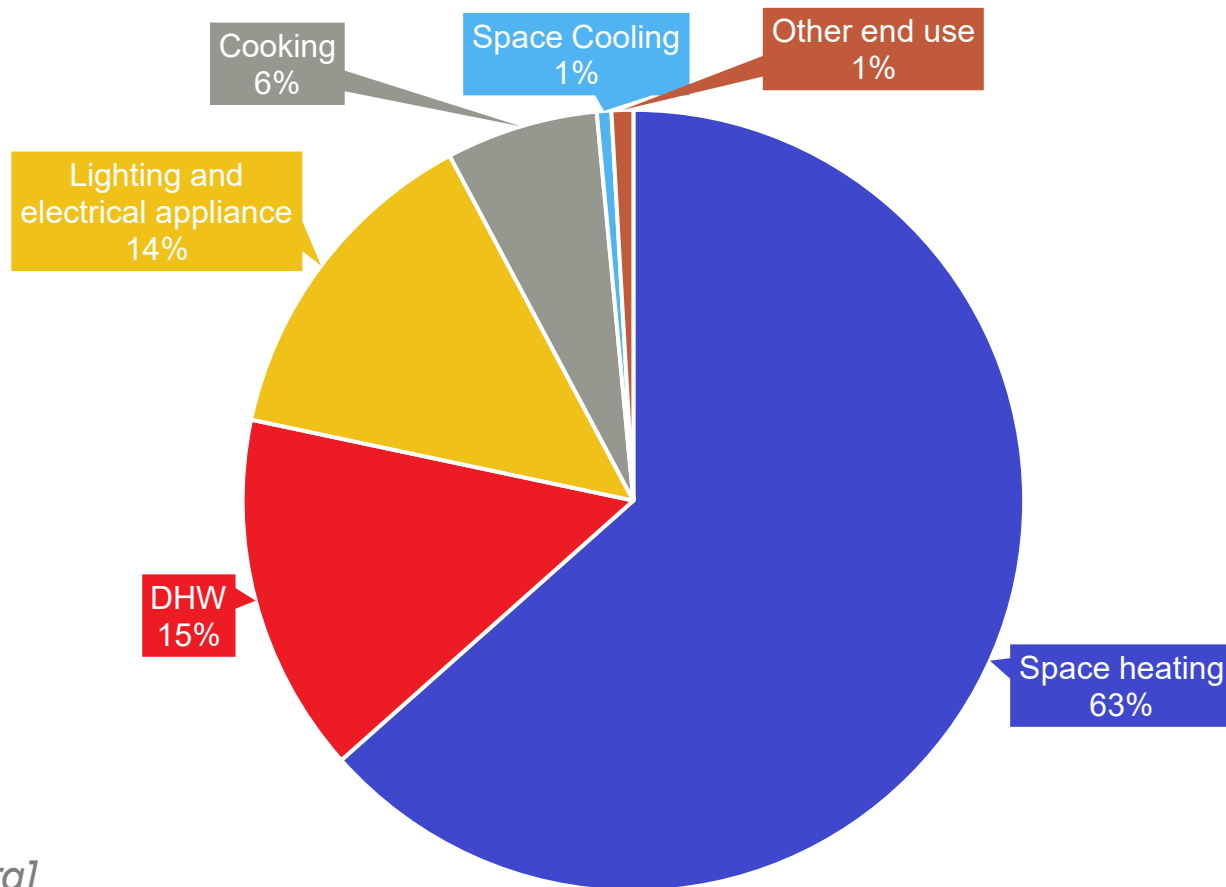

- The share of DHW final energy consumption in the residential sector in the EU represents 15 %
- The space heating and DHW consumptions are 1722 TWh



# 3. Description of the DHW needs

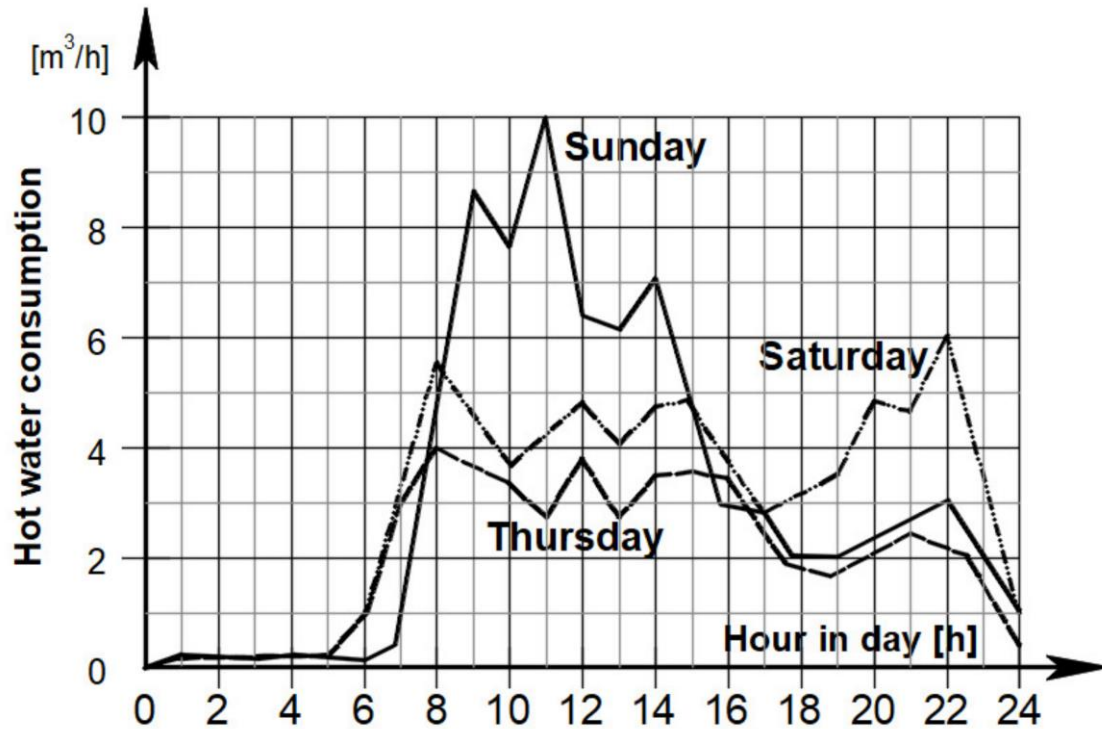

The DHW needs depend on the number and type of device (shower, dishwasher, ...), the time and the occupants (habit, number)

$$P_{DHW} = \rho C_p \dot{V}_{hw} (T_{hw} - T_{cw})$$

Diagram illustrating the DHW power requirement equation with parameter labels:

- Specific heat [kJ/kg/K] points to  $C_p$
- Density [kg/m³] points to  $\rho$
- Water flow rate [m³/s] points to  $\dot{V}_{hw}$
- Hot water temperature [K] or [°C] points to  $T_{hw}$
- Cold water temperature [K] or [°C] points to  $T_{cw}$

# 4. Description of the space cooling needs

Final energy consumption by use in residential sector EU 2022

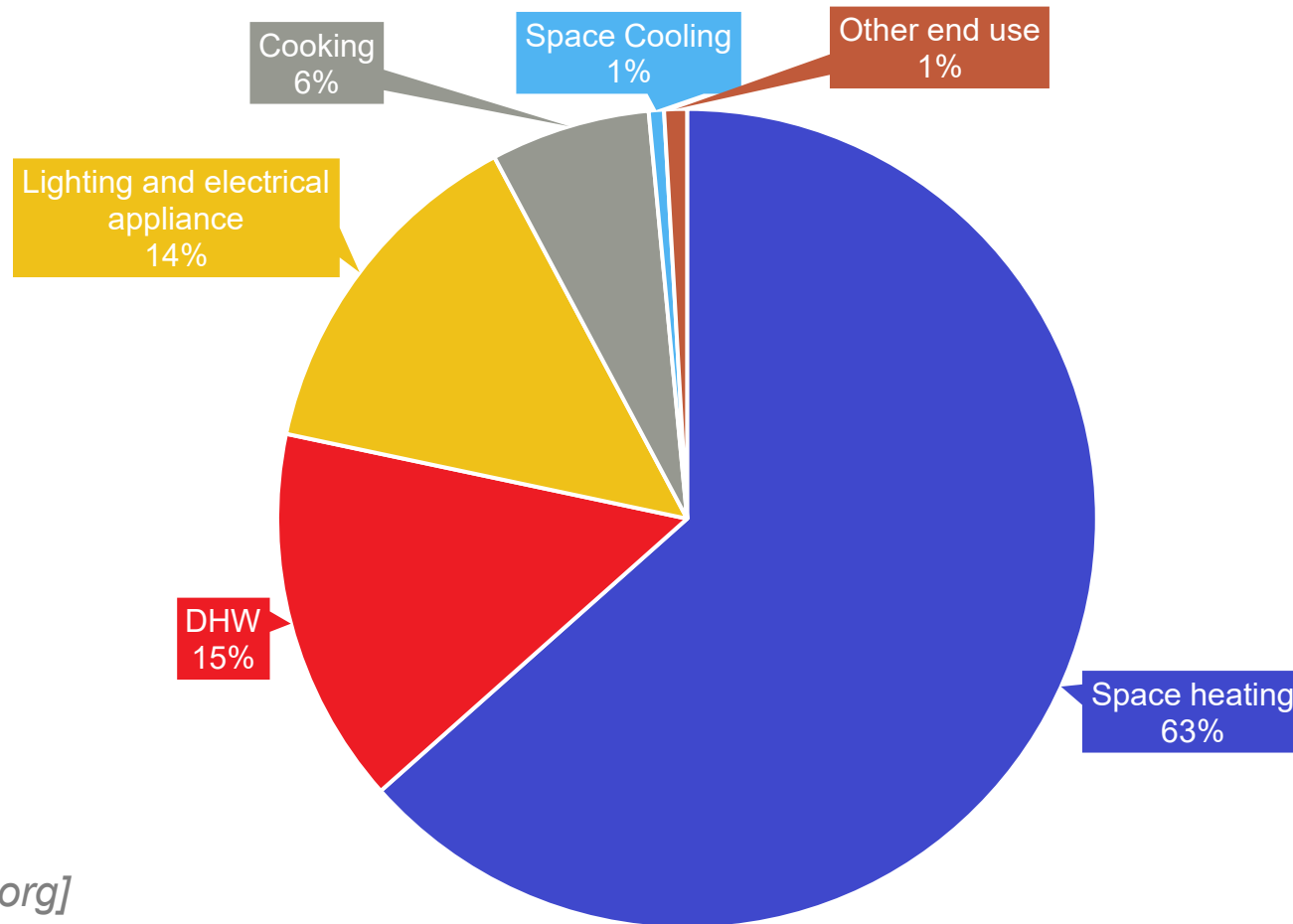

- The share of space cooling final energy consumption in residential sector in EU represents 1%
- The space cooling consumption is 22 TWh

4 x



# 4. Description of the space cooling needs

$$\dot{Q}_c = \dot{Q}_{gla} + \dot{Q}_v + \dot{Q}_w + \dot{Q}_i$$

Space cooling

Transmission  
(transparent) gains

Ventilation gains

Transmission  
(opaque) gains

Internal gains:



Fan-coil unit



glazing

Windows



Walls



Lights



Cooling  
floor/ceiling



Windows frame  
& door



Occupant



Electric  
appliance



Thank you!

Module 2.1 – Introduction  
SHaKE – Sharing Heat and Knowledge on Energy Communities

<https://www.shakeproject-dhc.eu/>

Developed by Mines Paris – PSL  
Antoine Fabre | [antoine.fabre@minesparis.psl.eu](mailto:antoine.fabre@minesparis.psl.eu)  
Pascal Stabat | [pascal.stabat@minesparis.psl.eu](mailto:pascal.stabat@minesparis.psl.eu)



Co-funded by  
the European Union

