

Module 5.3

Beyond substation: How to design the secondary side

SHaKE – Sharing Heat and Knowledge on Energy Communities
Erasmus+ KA220-HED Cooperation Partnerships in Higher Education
Developing institution: Mines Paris – PSL
Author: Dr. Antoine Fabre
Date: March 2026
Version 1.0



SHaKE
Sharing Knowledge on Energy Communities



1. Introduction

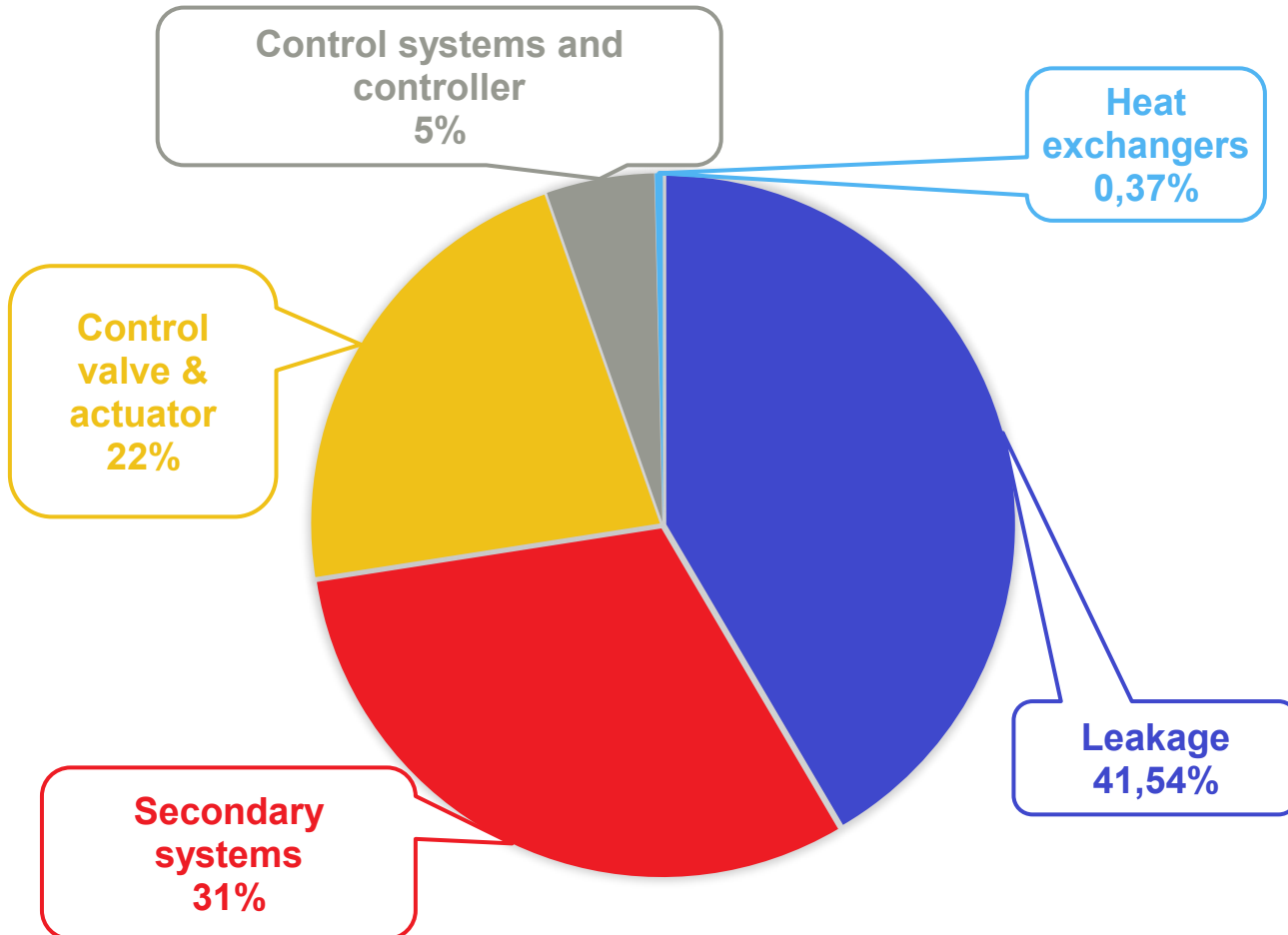

[Mansson & al, 2020]

- 31% of the malfunctions come from the secondary side
- Usually, the network undergoes the secondary side operation
- The DHC network in city centers are often connected to old buildings with old and not suitable systems.

1. Introduction

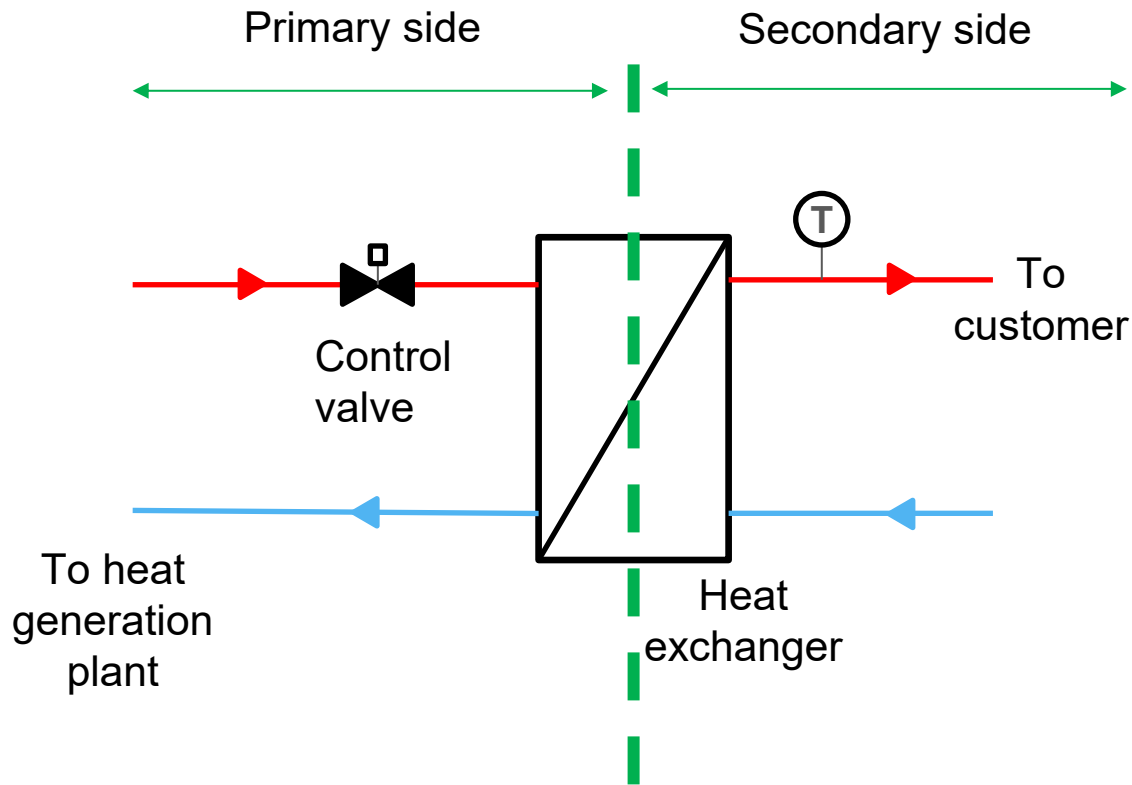

Usually, the DHC network operator only owns the primary side (including the heat exchanger and the secondary supply temperature sensor)



The DHC operator is generally not responsible for operation and maintenance of the secondary side



The operator has often limited knowledge of the equipment and how it operates on the secondary side

1. Introduction

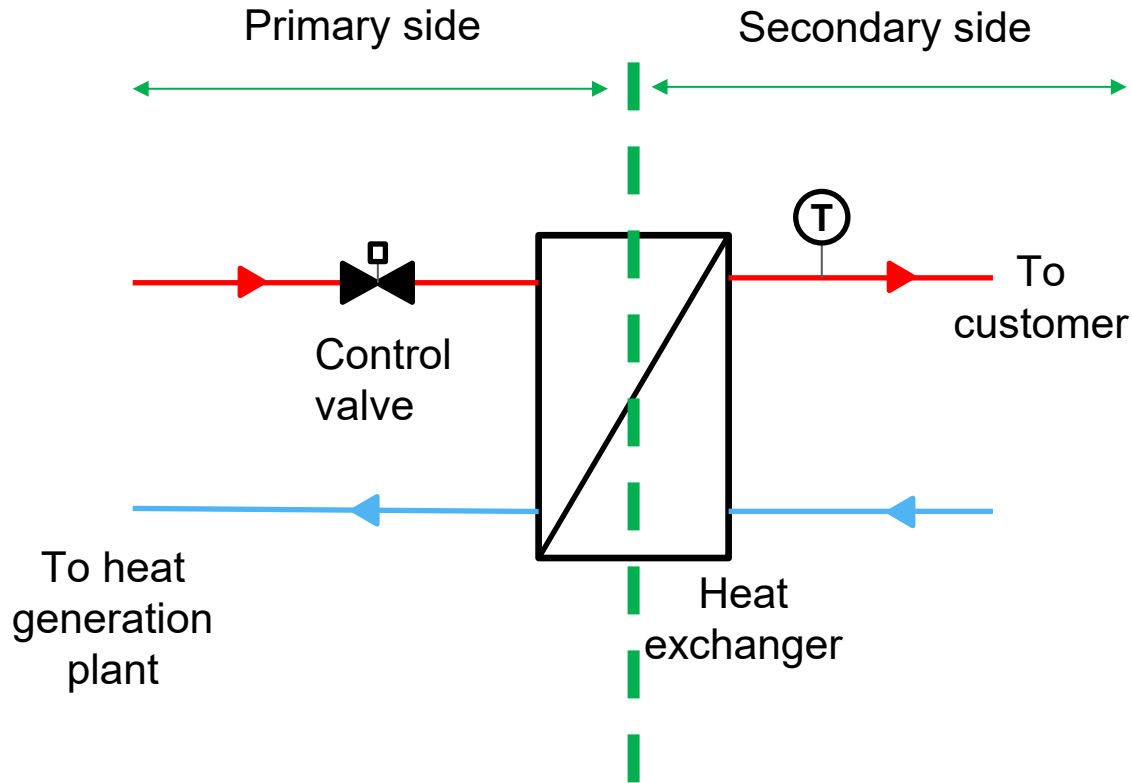

For billing purpose only exchanged power through the heat exchanger is legally mandatory. Usually, this data is measured through an energy meter (Two temperature sensors and one flow rate sensor)



Hence the secondary side data are limited which prevents DHC operators from determining whether there are any malfunctions on the building side

1. Introduction

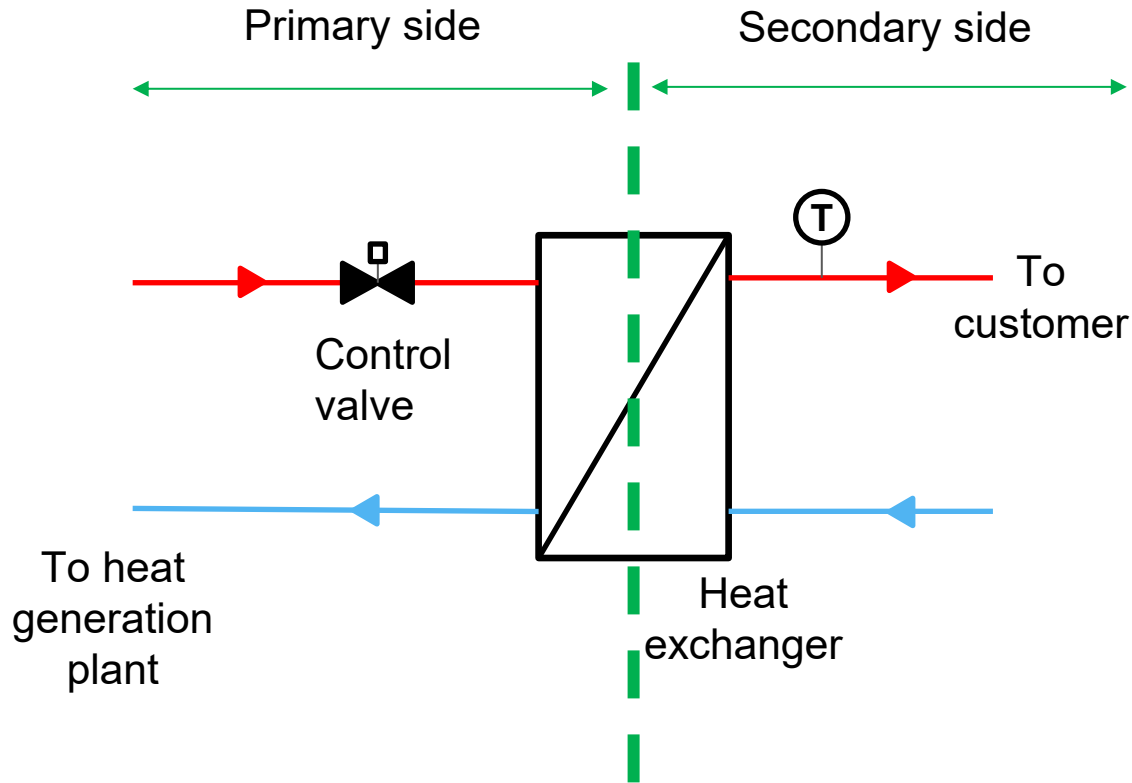

$$Total\ Tariff = Fixed\ Tariff + Variable\ Tariff$$

Subscription

Energy consumption



The actual classic heat tariff model is only impacted by the consumption not by the secondary side performance.



For customers, the refurbishment of the equipment will not impact directly the bill.

1. Introduction

$$\text{Total Tariff} = \text{Fixed Tariff} + \text{Variable Tariff} + \text{Incentive Tariff}$$

$$F_{\text{connection}} + F_{\text{capacity}}$$

- $F_{\text{connection}}$: cost depending on the distance between the heat generation site and the customer
- F_{capacity} : cost depending on the installed power

$$T_{MWh} + T_{m^3}$$

- T_{MWh} : cost of the energy consumed
- T_{m^3} : **cost of the water volume passing through the substation**

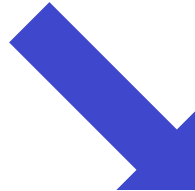
$$I_{T^\circ} + I_{\text{wasteheat}}$$

- I_{T° : **Incentive for reducing return temperature**
- $I_{\text{wasteheat}}$: **Incentive for the customer to make use of waste heat**

2. Design of the building side's hydronic systems

How does the secondary side (building side) work?

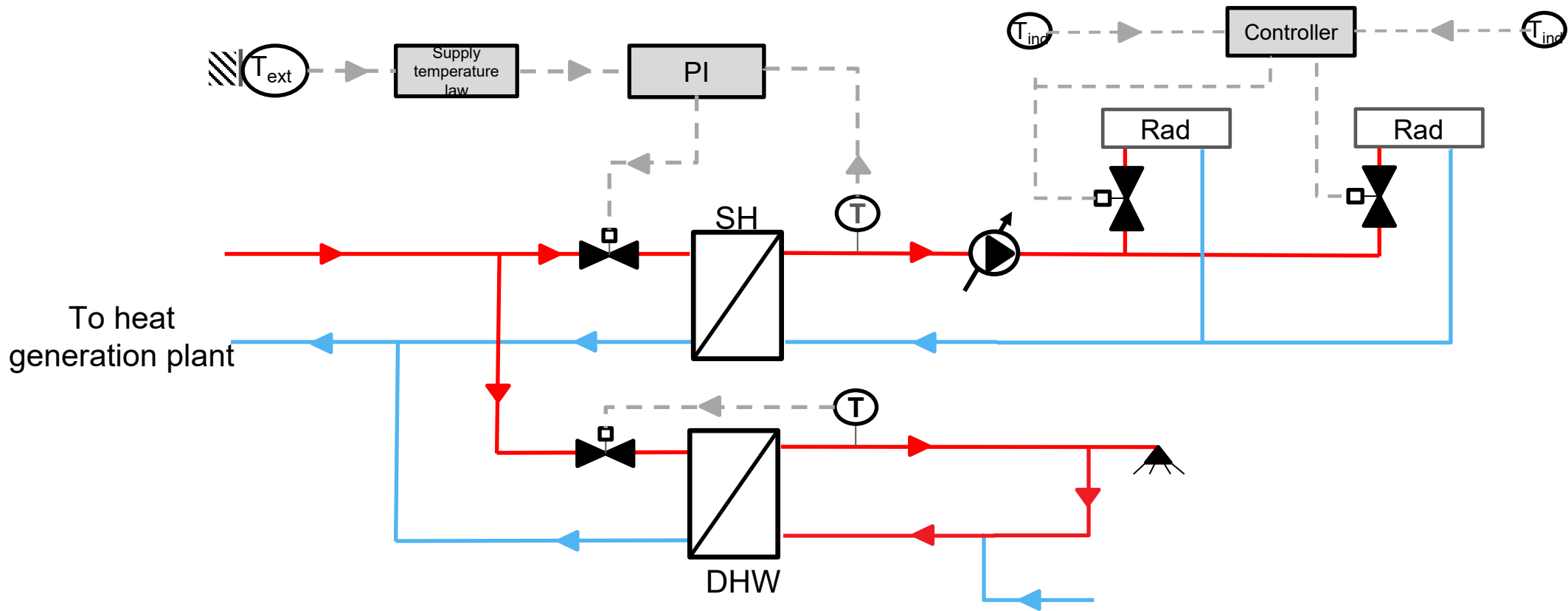

2.1 Emitters

Space Heating (SH)

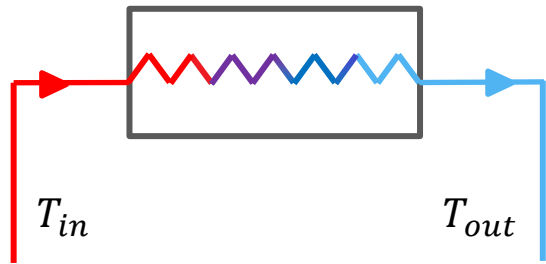

$$\dot{Q} = UA \left(\left(\frac{T_{in} + T_{out}}{2} \right) - T_{inside} \right)^n$$

Evolution of temperature regime of radiators
(T_{in}/T_{out} at $T_{out} = -7^\circ\text{C}$)

| Constructive period | Initial state | After renovation |
|---------------------|---------------|------------------|
| Before 1948 | 80/60 | 60/40 |
| 1948 - 1974 | 80/60 | 50/35 |
| 1975-1989 | 80/60 | 60/40 |
| After 1990 | 70/50 | 60/40 |

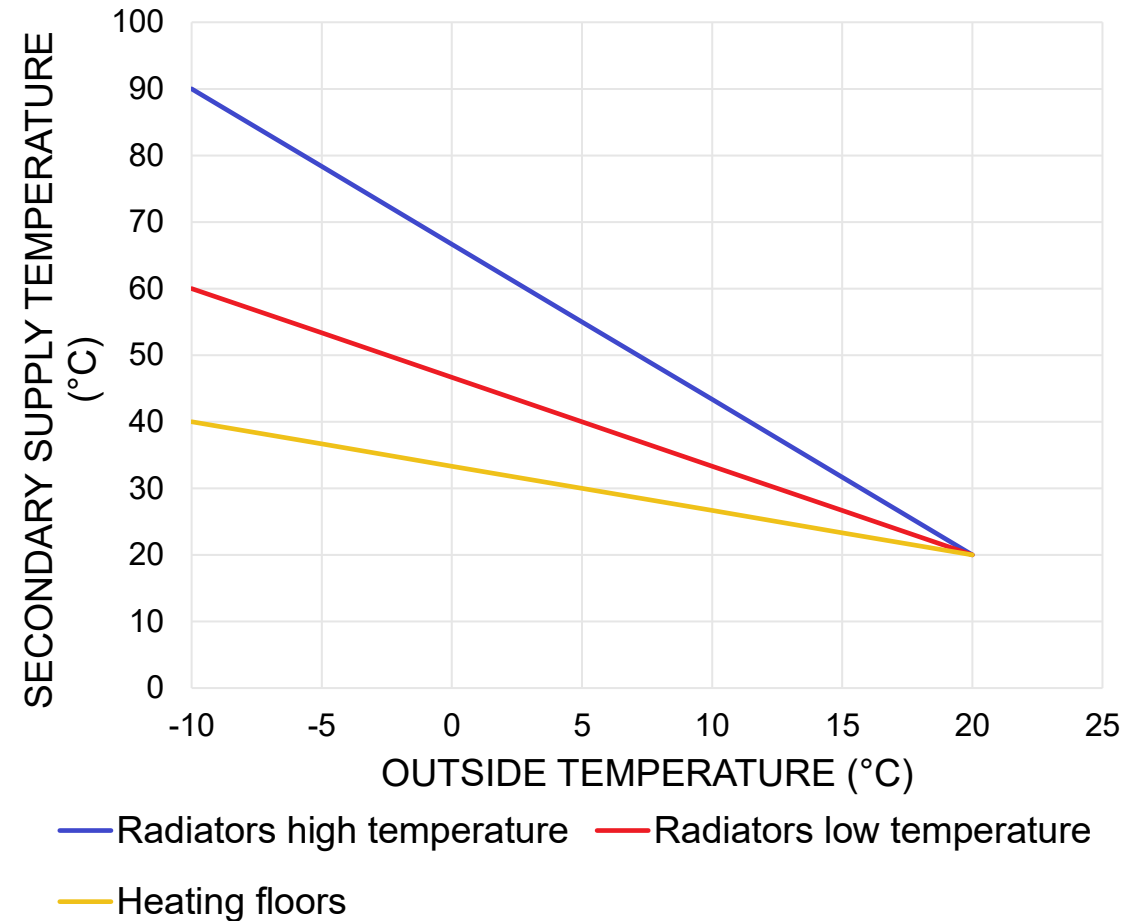

2.1 Emitters

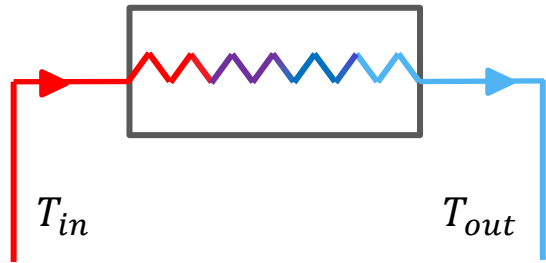

$$\dot{Q} = UA \left(\left(\frac{T_{in} + T_{out}}{2} \right) - T_{inside} \right)^n$$

Evolution of temperature regime of radiators
(T_{in}/T_{out} at $T_{out} = -7^\circ\text{C}$)

| Constructive period | Initial state | After renovation |
|---------------------|---------------|------------------|
| Before 1948 | 80/60 | 60/40 |
| 1948 - 1974 | 80/60 | 50/35 |
| 1975-1989 | 80/60 | 60/40 |
| After 1990 | 70/50 | 60/40 |

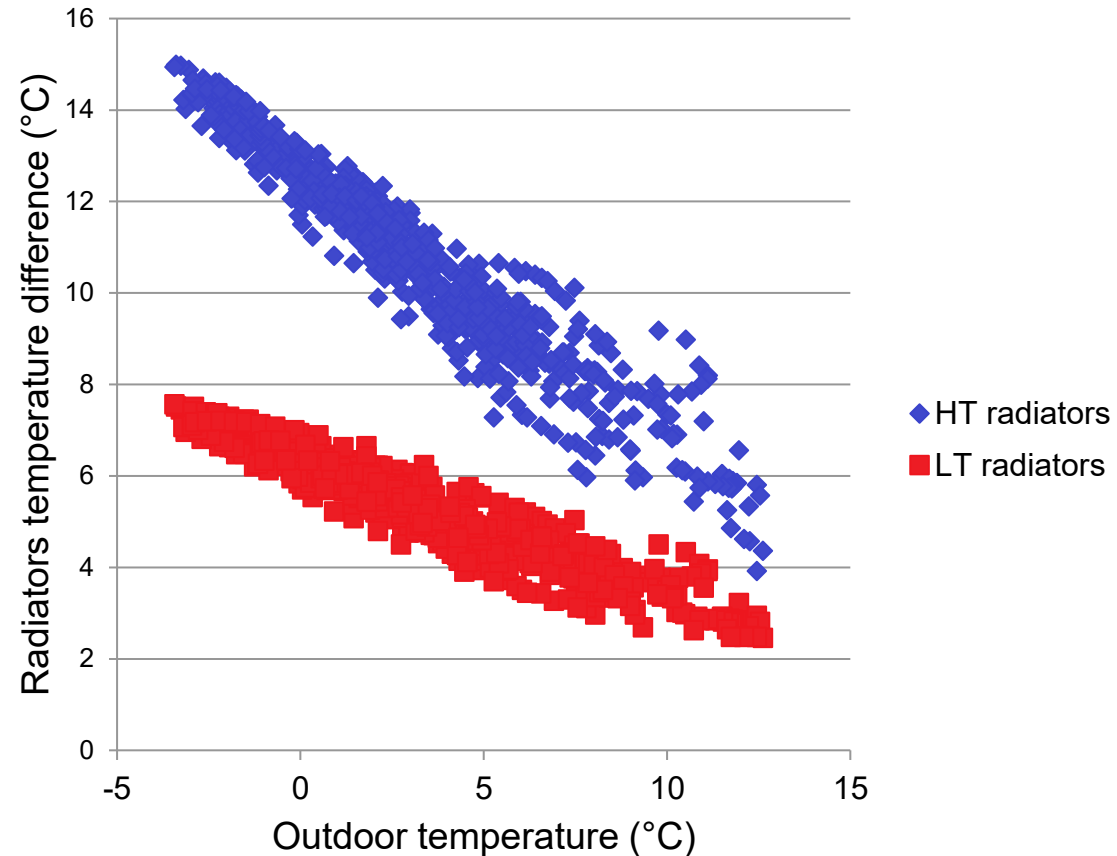

2.1 Emitters

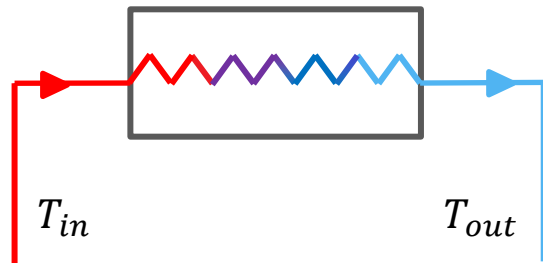

Evolution of temperature regime of radiators
(T_{in}/T_{out} at $T_{out} = -7^{\circ}\text{C}$)

| Constructive period | Initial state | After renovation |
|---------------------|---------------|------------------|
| Before 1948 | 80/60 | 60/40 |
| 1948 - 1974 | 80/60 | 50/35 |
| 1975-1989 | 80/60 | 60/40 |
| After 1990 | 70/50 | 60/40 |

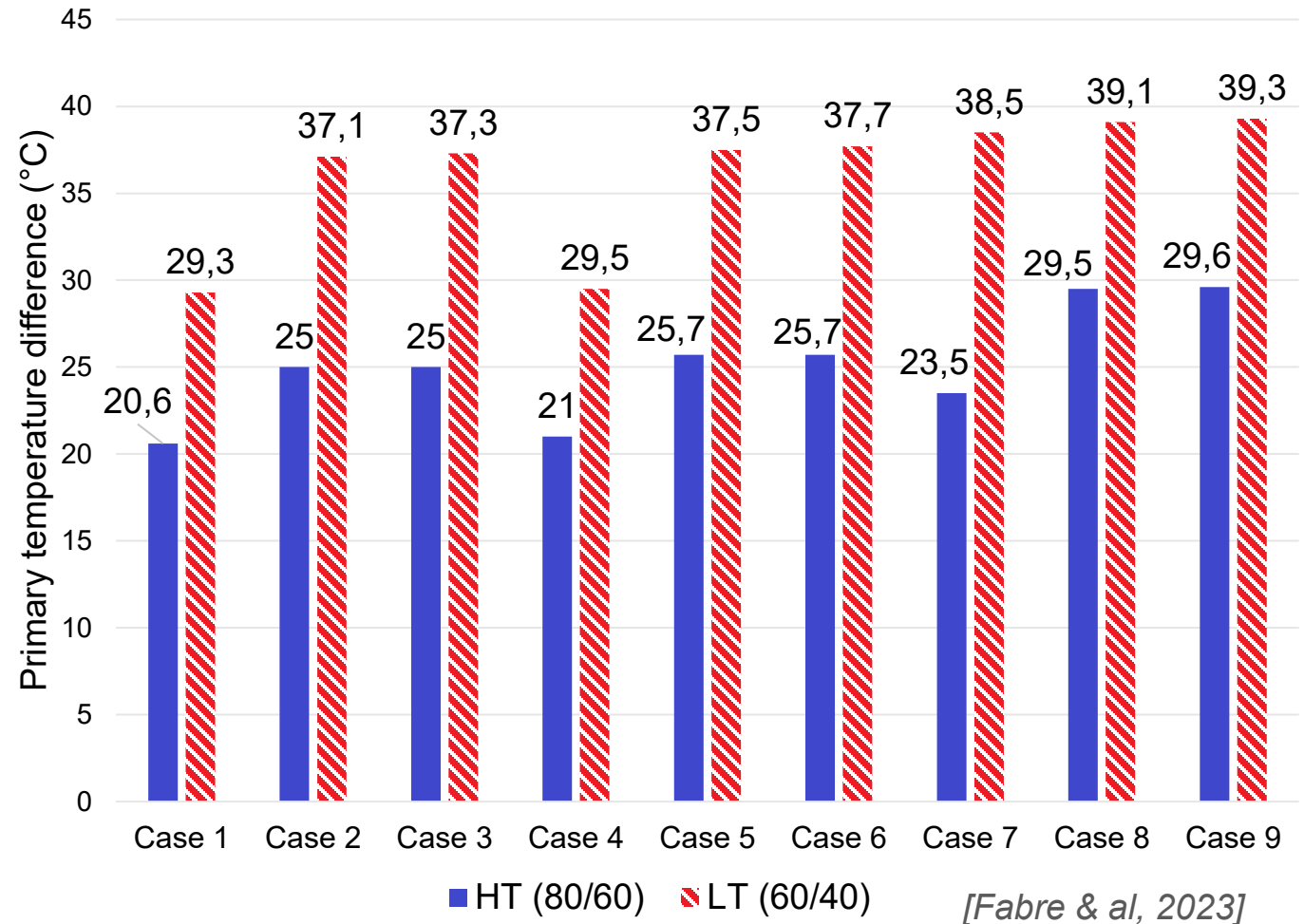

2.2 Valves and pumps

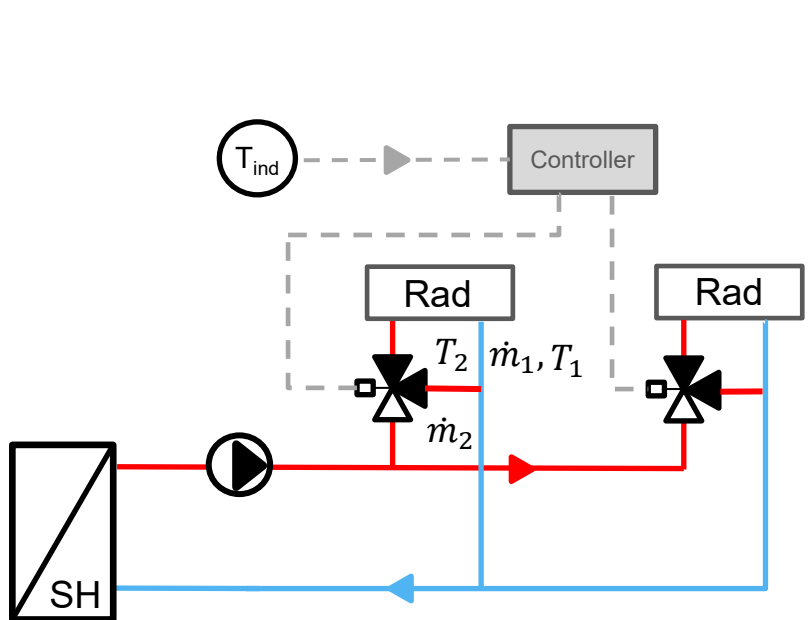

Three-way valves with constant mass flow rate pump

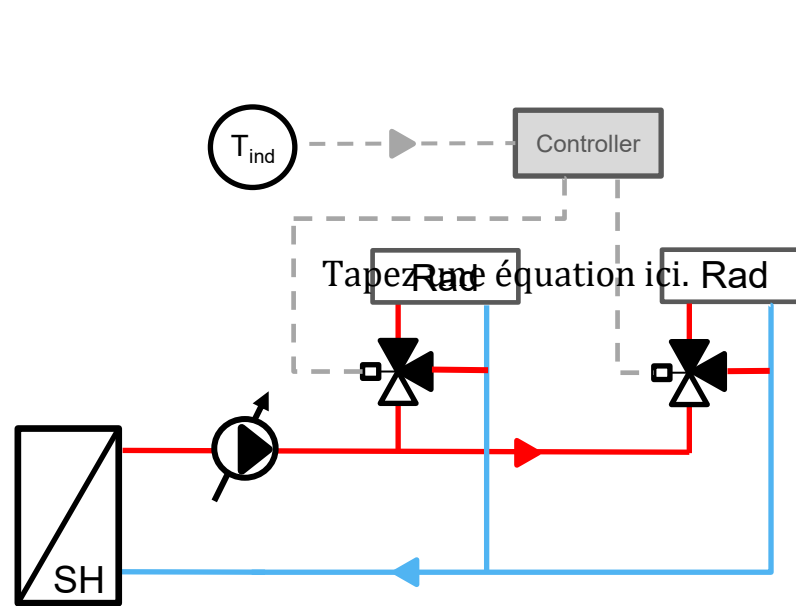

Three-way valves with variable mass flow rate pump

$$T_{mix} = \frac{T_1 \dot{m}_1 + T_2 \dot{m}_2}{\dot{m}_{tot}} \quad , \dot{m}_1 + \dot{m}_2 = \dot{m}_{tot}$$

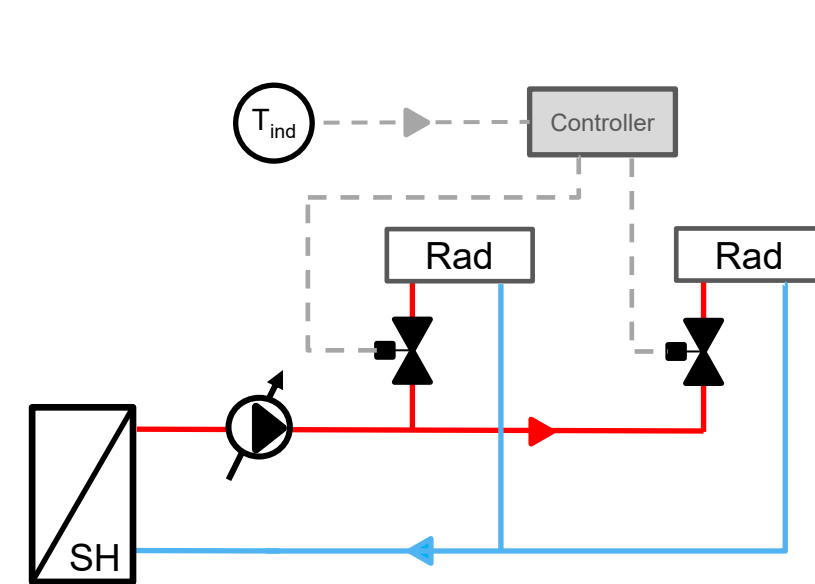

Two-way valves with variable mass flow rate pump

2.2 Valves and pumps

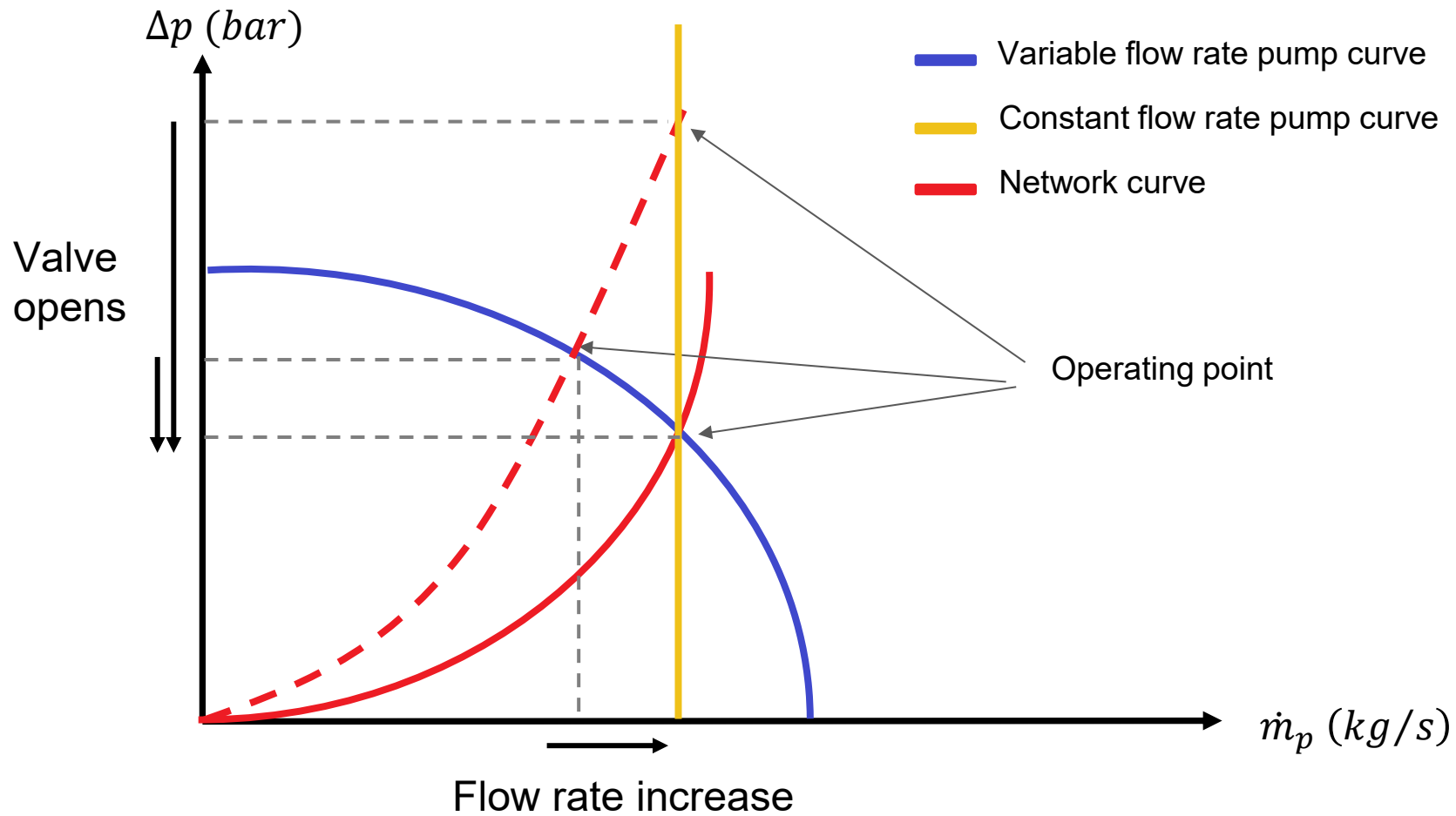

2.2 Valves and pumps



With V3V, a part of flow rate at the supply temperature is bypassed increasing the return temperature (the flow rate is design at the maximum demand)



The configuration with a V2V (or thermostatic valves) is the most performing one

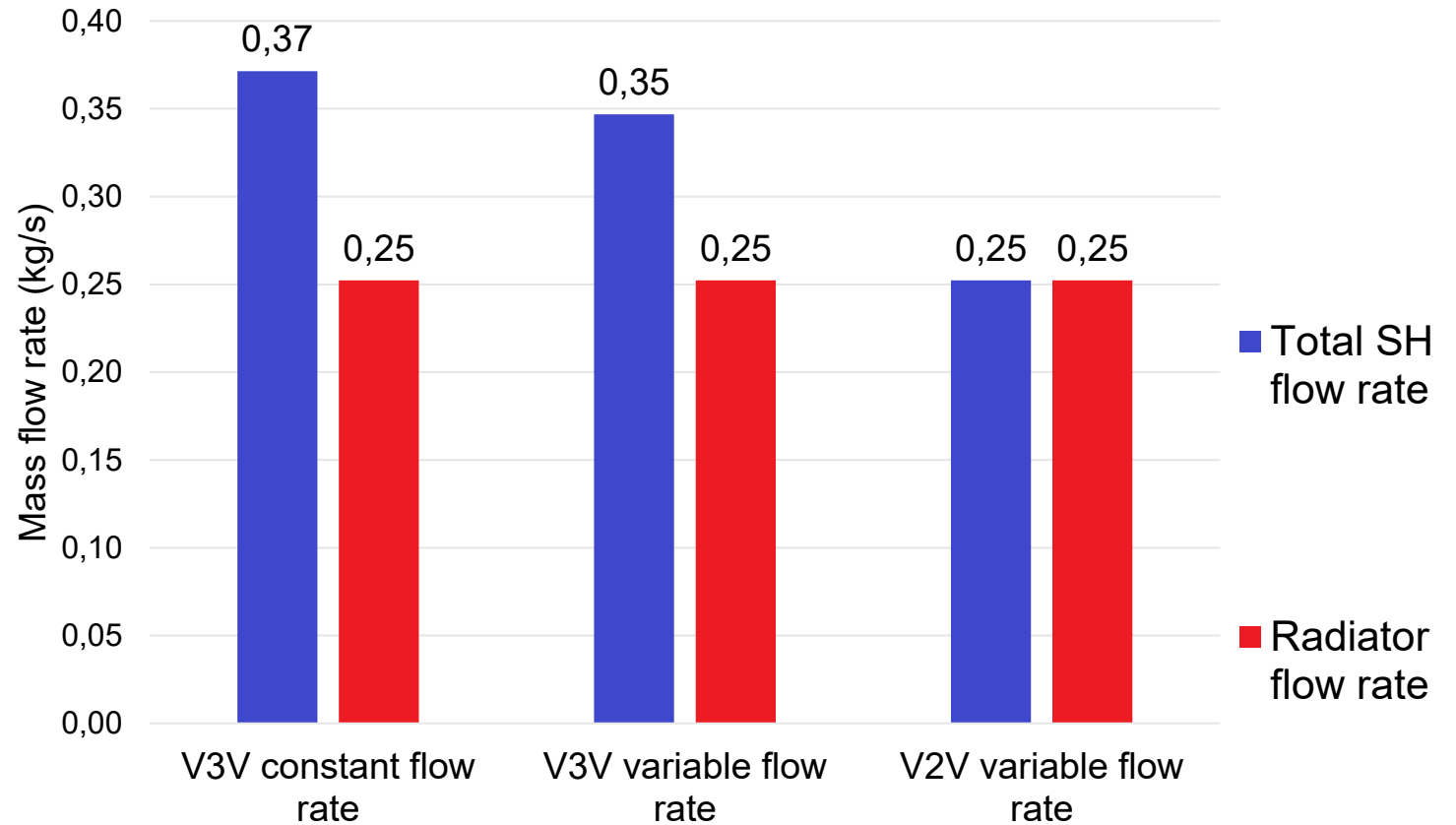

[Fabre & al, 2023]

2.2 Valves and pumps



With V3V, a part of flow rate at the supply temperature is bypassed increasing the return temperature (the flow rate is design at the maximum demand)



The configuration with a V2V (or thermostatic valves) is the most performing one

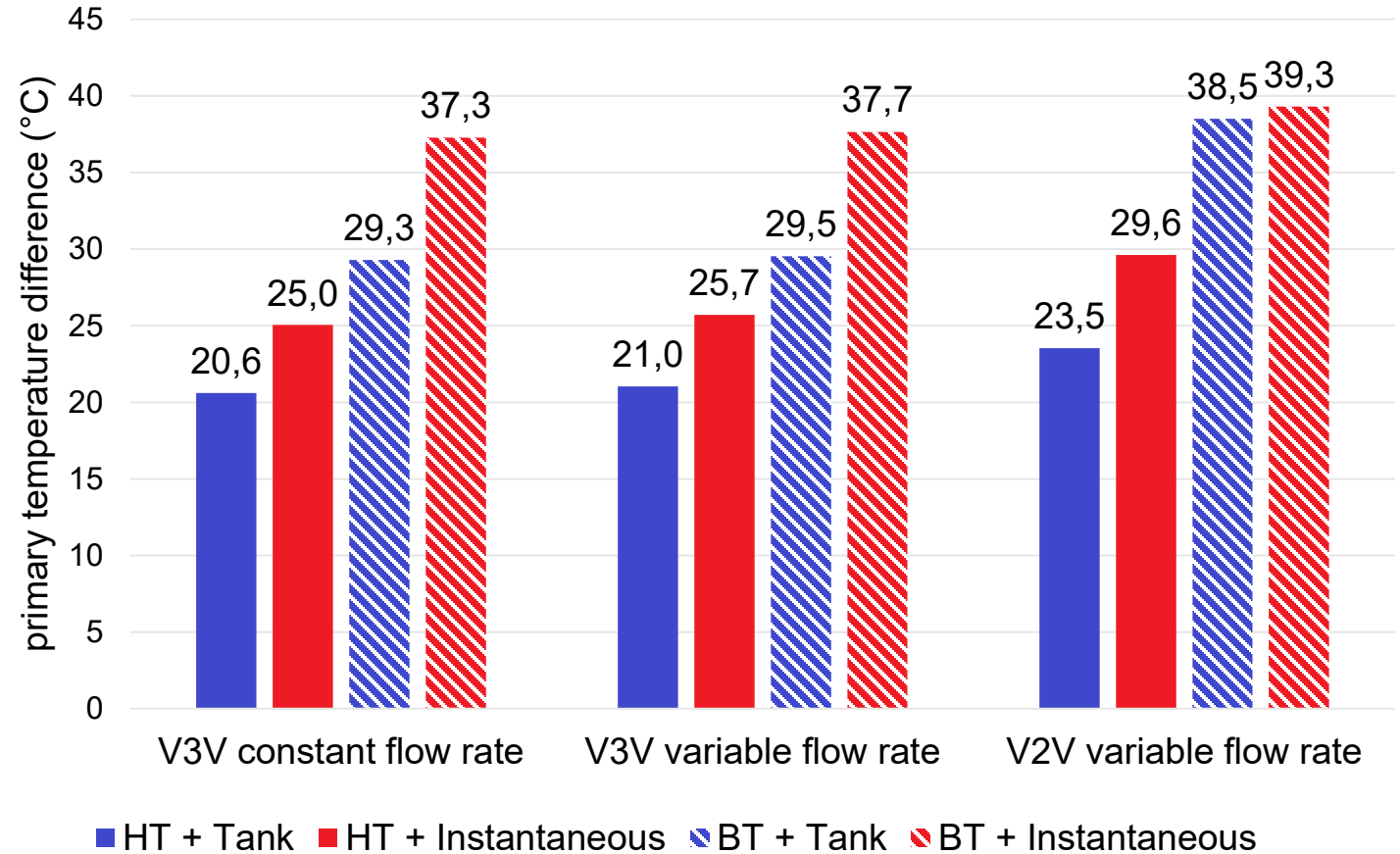

[Fabre & al, 2023]

2.3 DHW

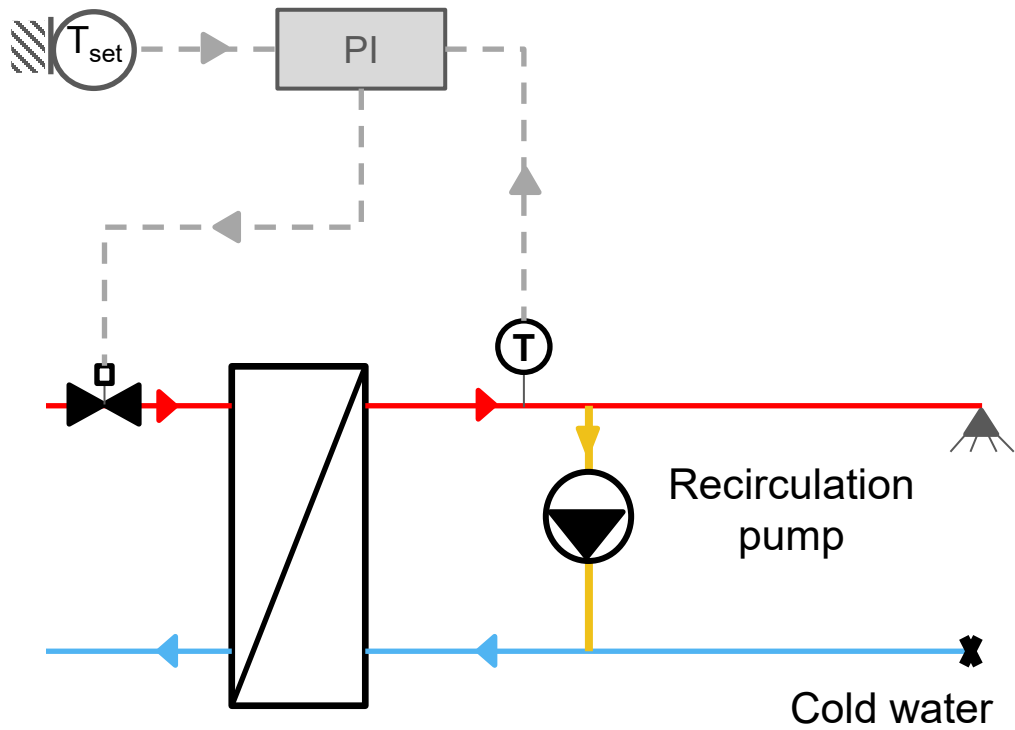

Instantaneous supply of DHW

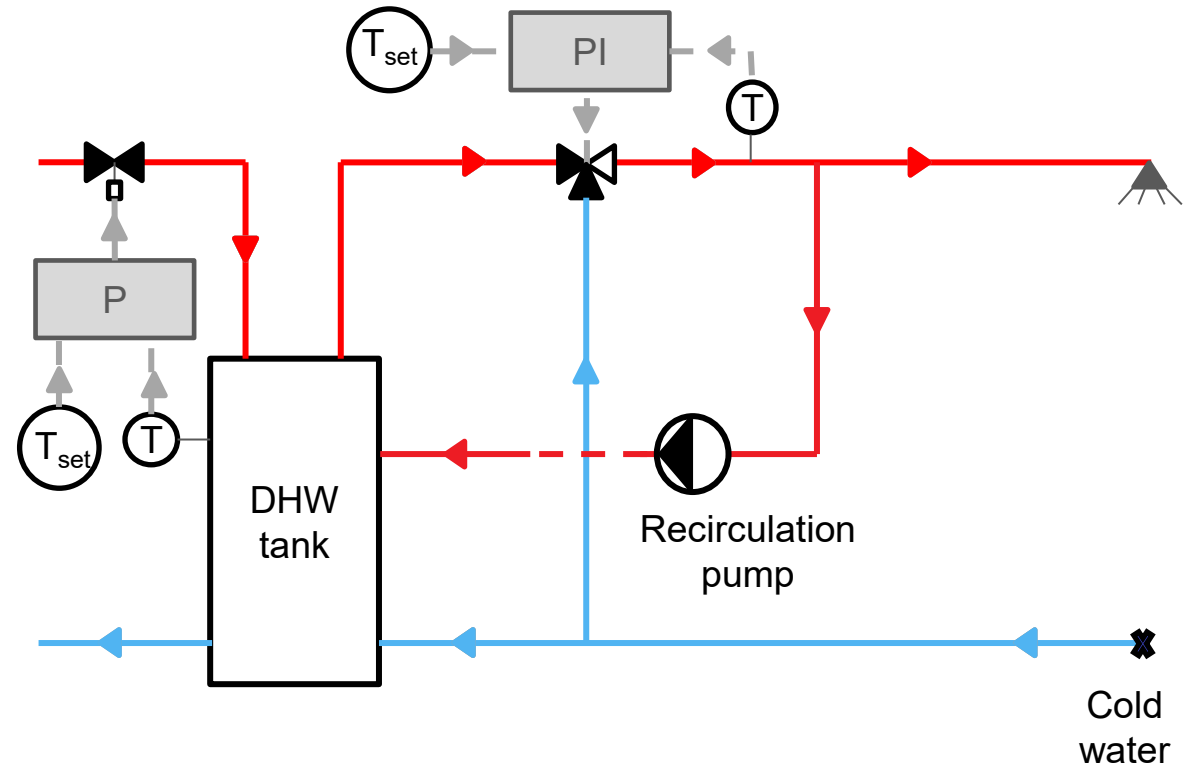

Supply of DHW through a tank (storage)

2.3 DHW

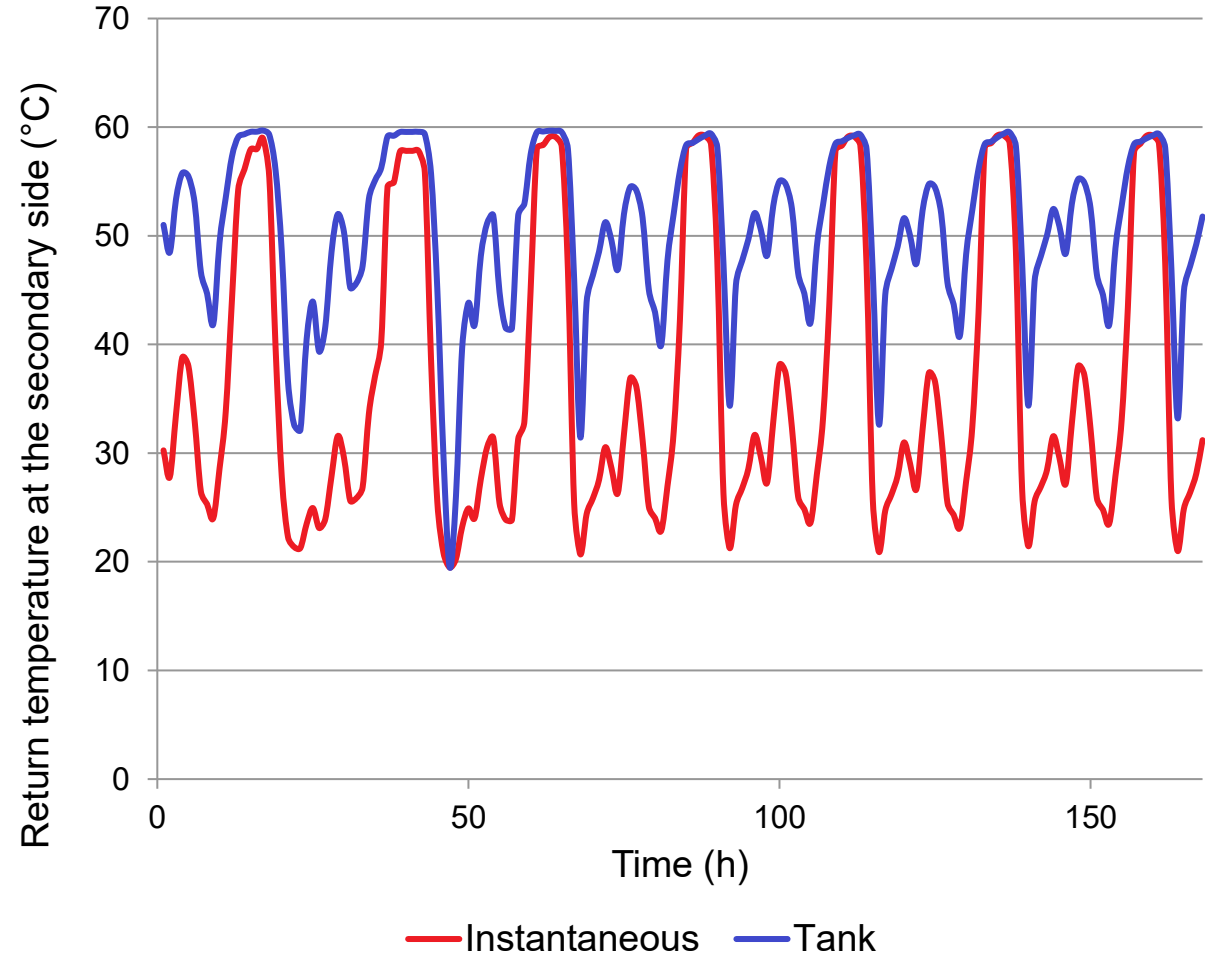
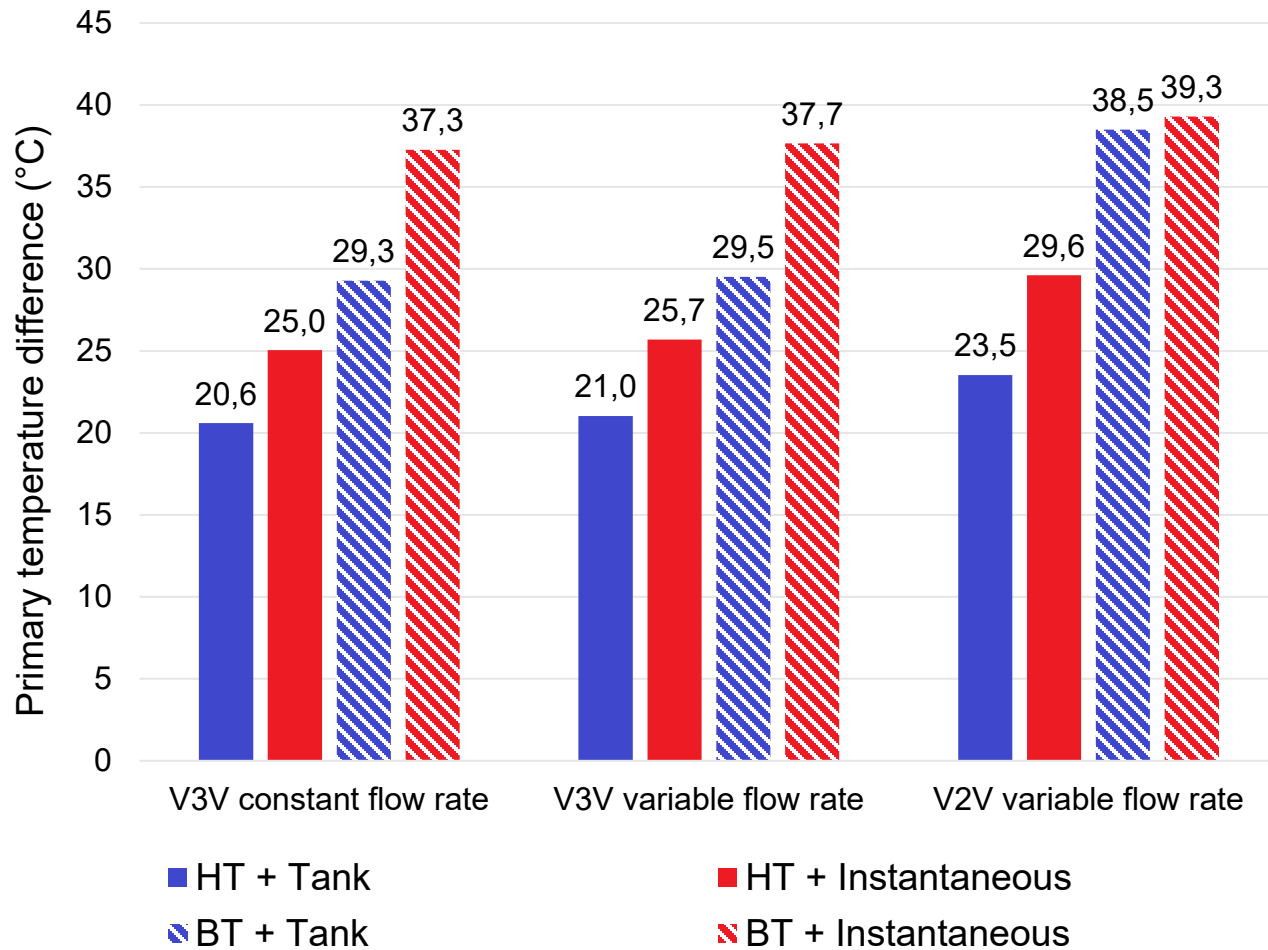

[Fabre & al, 2023]

2.3 DHW



With a DHW tank, the secondary return temperature is higher (no direct connection with the cold water)



The configuration without a tank is the most performing one

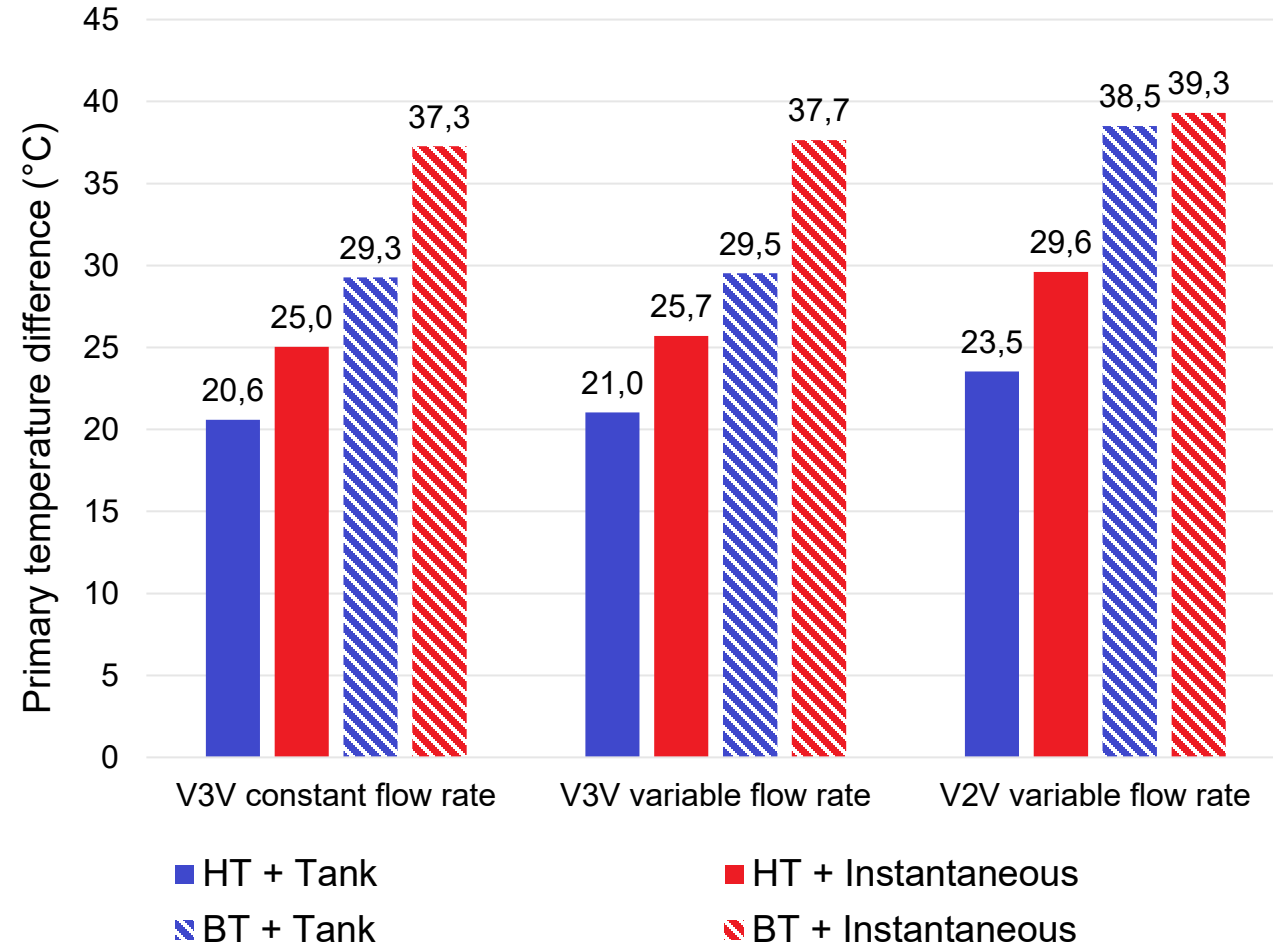

[Fabre & al, 2023]

2.4 Substation configuration

Parallel configuration

Cascade configuration

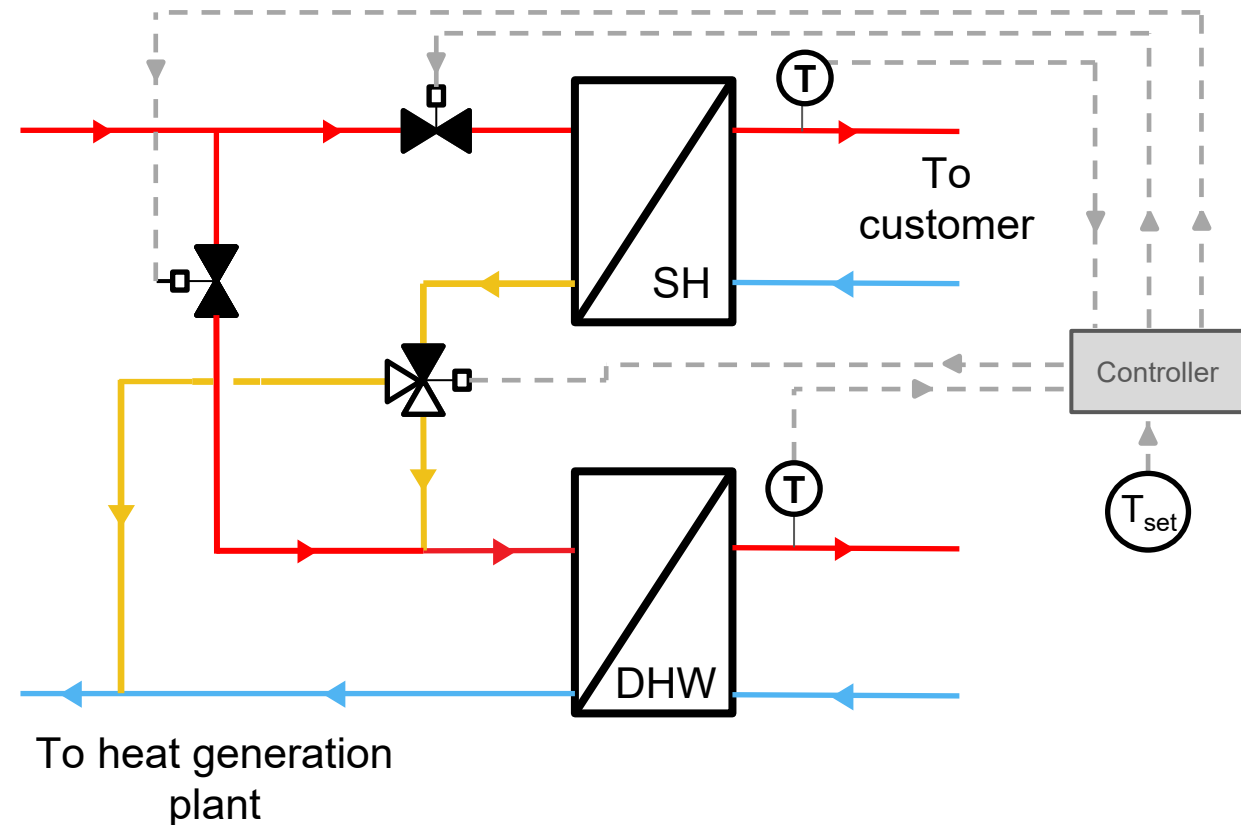
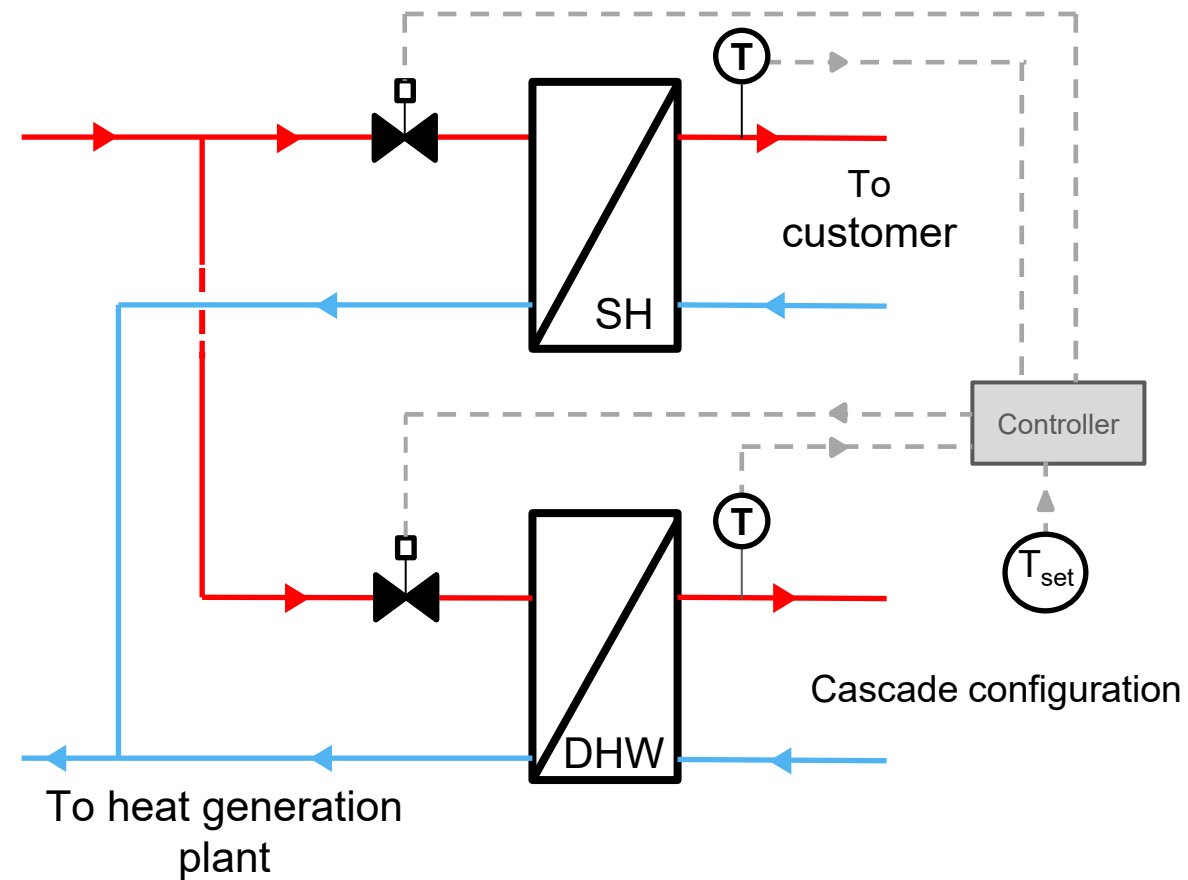

2.4 Substation configuration

Unique heat exchanger configuration

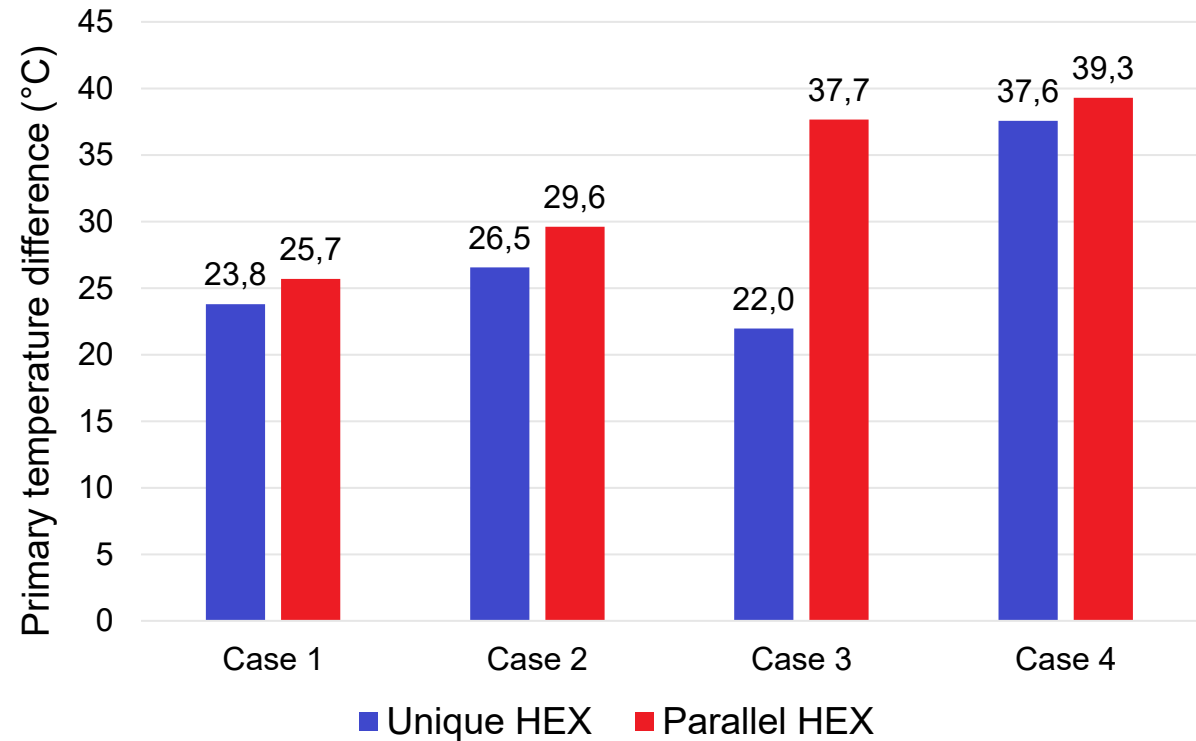
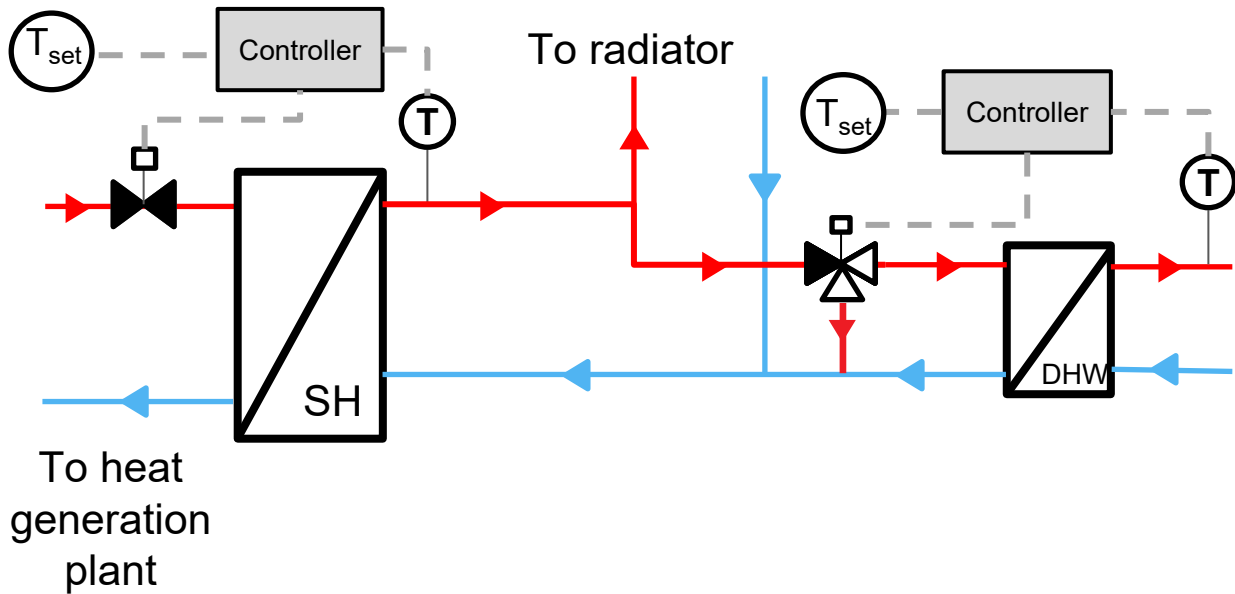

The parallel configuration is the most performing one

[Fabre & al, 2023]

3. Conclusion

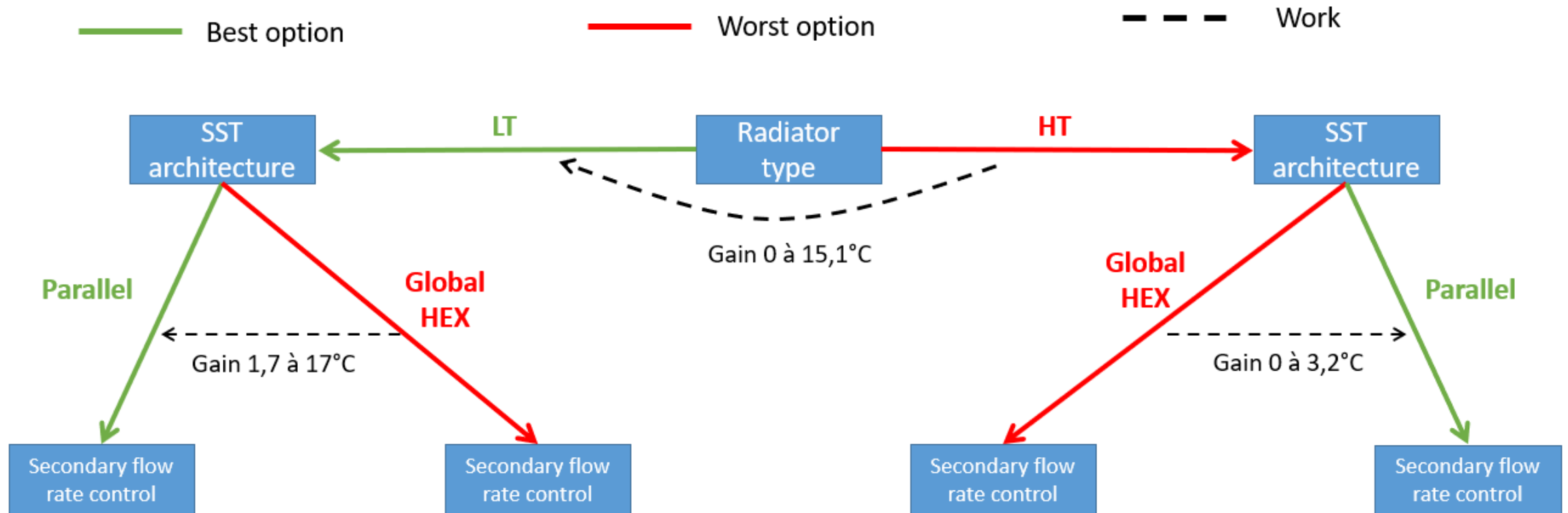

[Fabre & al, 2023]

3. Conclusion

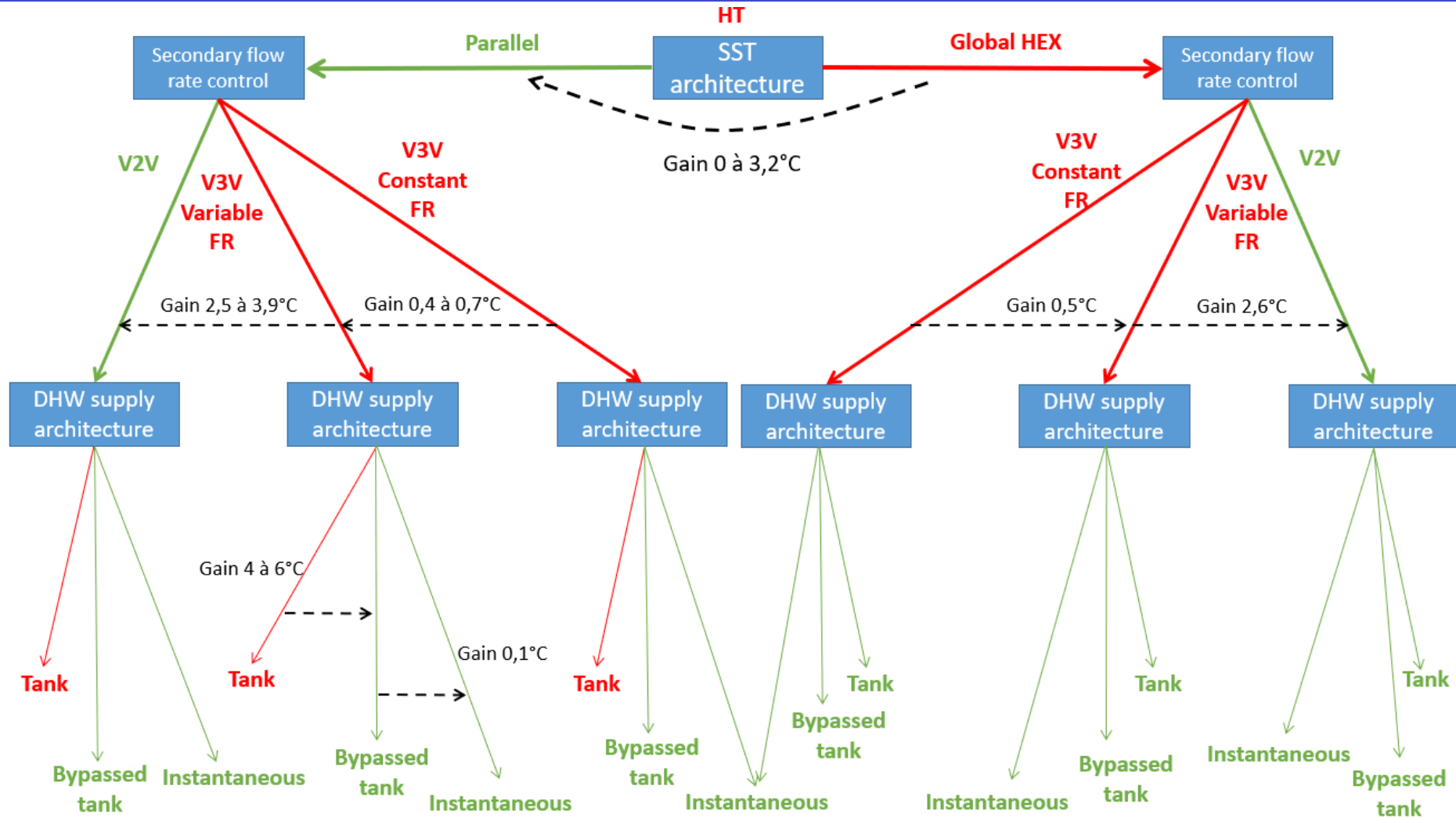

[Fabre & al, 2023]

3. Conclusion

$$\text{Total Tariff} = \text{Fixed Tariff} + \text{Variable Tariff} + \text{Incentive Tariff}$$



$$F_{\text{connection}} + F_{\text{capacity}}$$

- $F_{\text{connection}}$: cost depending on the distance between the heat generation site and the customer
- F_{capacity} : cost depending on the installed power



$$T_{MWh} + T_{m^3}$$

- T_{MWh} : cost of the energy consumed
- T_{m^3} : **cost of the water volume passing through the substation**

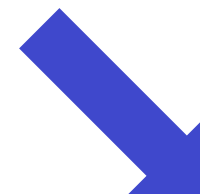

$$I_{T^\circ} + I_{\text{wasteheat}}$$

- I_{T° : **Incentive for reducing return temperature**
- $I_{\text{wasteheat}}$: **Incentive for the customer to make use of waste heat**

- **Fabre A., Duchayne C, Nyberg T., Gavan V., Lygnerud K., Stabat P.** Cost benefit study on the building secondary network for improving DH performance. *IEA DHC/CHP Report, 2023.*
- **Lygnerud, K., Nyberg, T., Nilsson, A.; Fabre A, Stabat P, Duchayne C., Gavan V.** A study on how efficient measures for secondary district heating system performance can be encouraged by motivational tariffs. *Energ Sustain Soc* **13**, 38 (2023). <https://doi-org.minesparis-psl.idm.oclc.org/10.1186/s13705-023-00417-0>
- **S. Månsson, P. O. Johansson Kallioniemi, M. Thern, T. Van Oevelen and K. Sernhed,** "Faults in district heating customer installations and ways to approach them: Experiences from Swedish utilities," *Energy*, vol. 180, pp. 163-174, 2019
<https://doi.org/10.1016/J.ENERGY.2019.04.220>



Thank you!

Module 5.3 – Beyond substation: How to design the secondary side

SHaKE – Sharing Heat and Knowledge on Energy Communities

<https://www.shakeproject-dhc.eu/>

Developed by Mines Paris – PSL
Antoine Fabre | antoine.fabre@minesparis.psl.eu
Pascal Stabat | pascal.stabat@minesparis.psl.eu



Co-funded by
the European Union

